

Resilient Gate Valve-Gland Type

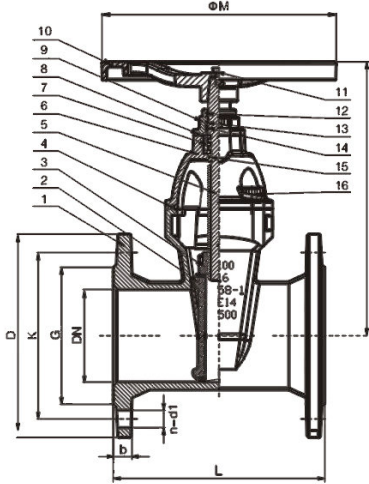

APPLICATION

SIZE	DN40-1000
CLASS	PN10/PN16/CL125/CL150
DESIGN	EN1171, EN1074-2
FACE TO FACE	EN558-1, ASME B16.10, AS2638
END FLANGE	EN1092-2, ASME B16.1/16.42, AS4087
TESTS	EN12266

MATERIAL LIST

STANDARD MATERIALS OF MAIN PARTS			
ITEM	PART NAME	MATERIAL	STANDARD
1	Body	GGG50/GJS500	DIN 1693/BSEN1563
2	Disc	GGG50+EPDM	DIN 1693
3	Stem Nut	CuZn39Pb1	EN12167
4	Bonnet Gasket	NBR	ISO 4633
5	Stem	X20CR13/420	EN10088-1/ASTM A959
6	Bonnet	GGG50/GJS500	DIN 1693/BSEN1563
7	Holding Ring	CuZn39Pb1	EN12167
8	O Ring	NBR	ISO 4633

STANDARD MATERIALS OF MAIN PARTS			
ITEM	PART NAME	MATERIAL	STANDARD
9	Gland	GGG50/GJS500	DIN 1693/BSEN1563
10	Handwheel	GGG50/GJS500	DIN 1693/BSEN1563
11	Bolts	C45E/1045	EN 10083-2/ASTM A29
12	Dust Ring	NBR	ISO 4633
13	O Ring	NBR	ISO 4633
14	Washer	Nylon 66	
15	U Ring	EPDM	ISO 4633
16	Screw	C45E/1045	EN 10083-2/ASTM A29

DIMENSIONS

DN	OUTLINE mm					END FLANGE PN10/16-CL125/150 mm								
	BS 5163	DIN -F4	DIN -F5	ASME 16.10	AS 2638	EN1092-2			ASME B16.1/B16.42			AS4087		
						D	K	n-d	D	K	n-d	D	K	n-d
40	165	140	240	-	-	150	110	4-Φ19	127	98.5	4-Φ16	-	-	-
50	178	150	250	178	-	165	125	4-Φ19	152	120.5	4-Φ19	-	-	-
65	190	170	270	190	-	185	145	4-Φ19	178	139.5	4-Φ19	-	-	-
80	203	180	280	203	203	200	160	8-Φ19	191	152.5	4-Φ19	185	146	4-Φ18
100	229	190	300	229	229	220	180	8-Φ19	229	190.5	8-Φ19	215	178	8-Φ18
125	254	200	325	254	-	250	210	8-Φ19	254	216	8-Φ22	-	-	-
150	267	210	350	267	267	285	240	8-Φ23	279	241.5	8-Φ22	280	235	8-Φ18
200	292	230	400	292	292	340	295	8-Φ23/12-Φ23	343	298.5	8-Φ22	335	292	8-Φ18
250	330	250	450	330	330	395/405	350/355	12-Φ23/12-Φ28	406	362	12-Φ25	405	356	8-Φ22
300	356	270	500	356	356	445/460	400/410	12-Φ23/12-Φ28	483	432	12-Φ25	455	406	12-Φ22