

## Globe Valve

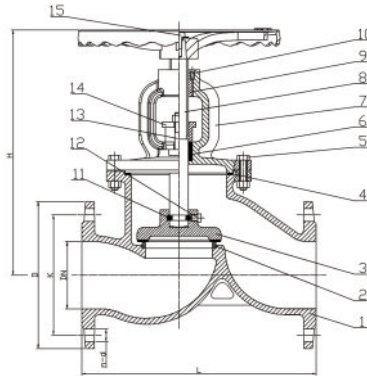

### APPLICATION

SIZE	DN50-300
CLASS	PN10/16 CL125/150
DESIGN	DIN 3356, BS5152, MSS SP-85
FACE TO FACE	DIN3202-F1, BS5152, ASME B16.10
END FLANGE	EN1092-2, ASME B16.1/16.42, AS4087
TESTE	EN12266

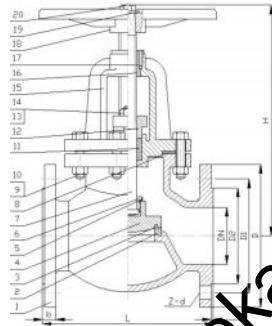

### MATERIAL LIST

#### STANDARD MATERIALS OF MAIN PARTS

PART NAME	MATERIAL	STANDARD
Body	GG25/GGG50	DIN 1693/BS EN1561
Seat Ring	CuZn39Pb2/C37000	EN12167/ASTM B135
Disc	GGG50	DIN 1693/BS EN1561
Bonnet Gasket	NBR/EPDM	ISO4633
Packing	Graphite	
Bonnet	GG25/GGG50	DIN 1693/BS EN1561
Stem	X20Cr13420	EN10088-1/ASTM A959
Stem Nut	CuZn39Pb2	EN12167
Screws	C45/1045	EN10083/ASTM A29
Bolt	C45/1045	EN10083/ASTM A29
Gland	GG25/GGG50	DIN 1693/BS EN1561
Handwheel	GG25/GGG50	DIN 1693/BS EN1561

### DIMENSIONS

DN	OUTLINE mm				END FLANGE PN10/16-CL125/150 mm								
	L		H		EN1092-2			ASME B16.1/B16.42			AS4087		
	DIN-F1	BS5152/ASME B16.10	DIN-F1	BS5152/ASME B16.10	D	K	n-d	D	K	n-d	D	K	n-d
50	230	203	270	270	165	125	4-Φ19	152	120.5	4-Φ19	-	-	-
65	290	216	280	298	185	145	4-Φ19	178	139.5	4-Φ19	-	-	-
80	310	241	330	310	200	160	8-Φ19	191	152.5	4-Φ19	185	146	4-Φ18
100	350	292	365	352	220	180	8-Φ19	229	190.5	8-Φ19	215	178	4-Φ18
125	400	330	405	375	250	210	8-Φ19	254	216	8-Φ22	-	-	-
150	480	356	435	425	285	240	8-Φ23	279	241.5	8-Φ22	280	235	8-Φ18
200	600	495	520	515	340	295	8-Φ23/12-Φ23	343	298.5	8-Φ22	335	292	8-Φ18
250	730	622	650	615	395/405	350/355	12-Φ23/12-Φ28	406	362	12-Φ25	405	356	8-Φ22
300	850	698	680	760	445/460	400/410	12-Φ23/12-Φ28	483	432	12-Φ25	455	406	12-Φ22