

## SLEEVE TYPE SOFT SEAL PLUG VALVE

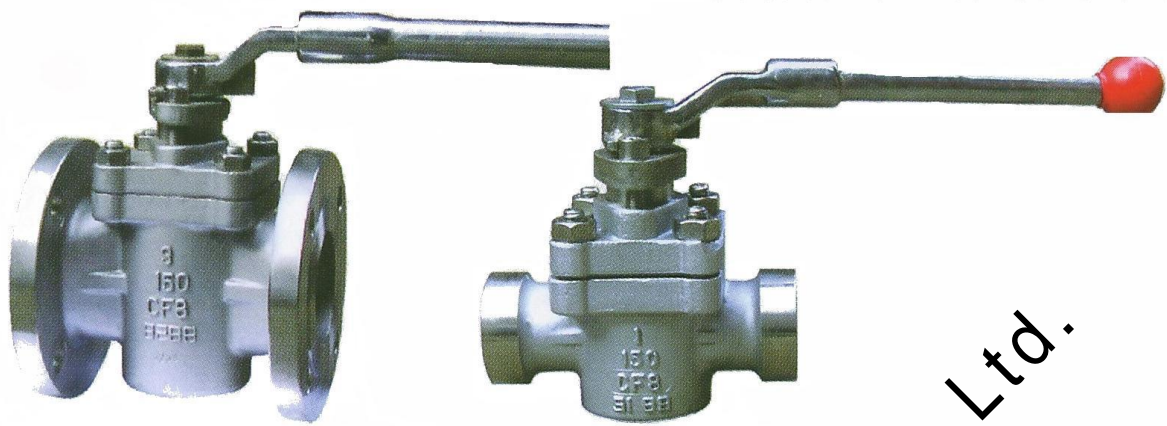

### FEATURES

Sleeve type soft sealing plug valve according to ANS is applicable to the cutting and connection of pipeline's medium that aroused in various industries such as petroleum, chemical industry, pharmacy, chemical fertilizer, power industry etc. It is under nominal pressure of CLASS150-300LBS, and works at the temperature of -29~+180°C.

- a. The product has reasonable structure, reliable sealing, excellent performance and beautiful appearance.
- b. Its sealing is realized by the sealing face around the sleeve. It has unique 360 degree metal edge for protection and fixing of the sleeve.
- c. There is no cavity in the valve for the accumulation of medium.
- d. Metal edge provides the function of self-cleaning when the plug is rotated. It is applicable to the operation condition that is glutinous sand apt to smudge.
- e. Its double-direction flow makes installation and use more convenient.
- f. The materials of the parts and sizes of flanges can be configured reasonably according to the actual operation condition the customer required, so as to meet the various needs of engineering.

### TECHNICAL SPECIFICATIONS

Body Structure	BB-BG-OS & Y
Operating Model	Wrench, hand wheel, worm gear, pneumatic, electric-actuated
Design Standard	AP1599, AP16D
Face to Face	ASME B16.10
Flanged End	ASME B16.5
Butt-welded End	ASME B16.25
Test & Inspection	AP1598, AP16D

**Note:** size of serial valve connecting can be designed according to customer's requirement

### PRESSURE SPECIFICATIONS

PN(LB)	Shell Test (MPa)	Sealing Test (MPa)	Applicable Temperature	Applicable Medium
150	3.0	2.2	≤180°C	W.O.G
300	7.5	5.5		
600	15.0	11.0		
900	22.5	16.5		

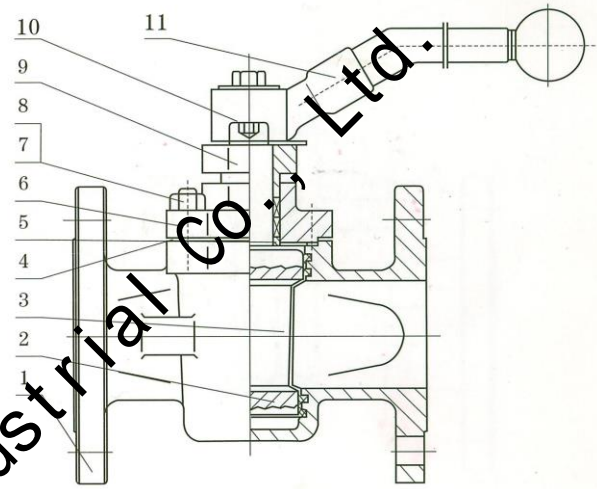
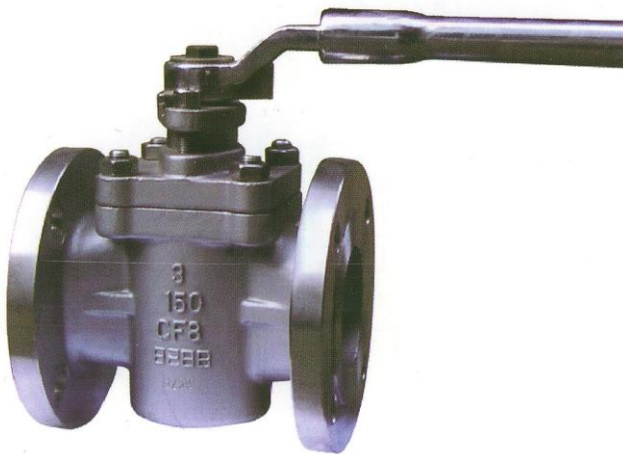

### MAIN PARTS MATERIALS

NO	Part name	Material
1	Body	ASTM A216-WCB, ASTM A351-CF8, CF8M, CF3, CF3M
2	Sleeve	PTFE
3	Plug	ASTM A217-WC1, WC6, WC9, C5, ASTM A351-CF8, CF8M, CF3, CF3M
4	Gasket	PTFE
5	Adjusting gasket	ASTM A182-F304, F316, F321, F304L, F316 ASTM A182-Gr.F6a ASTM A182-F22
6	Cover	ASTM A216-WCB ASTM A351-CF8, CF8M, CF3, CF3M
7	Bolt	ASTM A194-2H, A194-8, A194-8M
8	Nut	ASTM A194-2H, A194-8, A194-8M
9	Adjusting Gland	ASTM A216-WCB ASTM A351-CF8, CF8M, CF3, CF3M
10	Nut	ASTM A193-B7,A193-B8,A193-B8M
11	Wrench	ASTM A216-WCB



**LUOKAI**  
WE MAKE FLOW BETTER

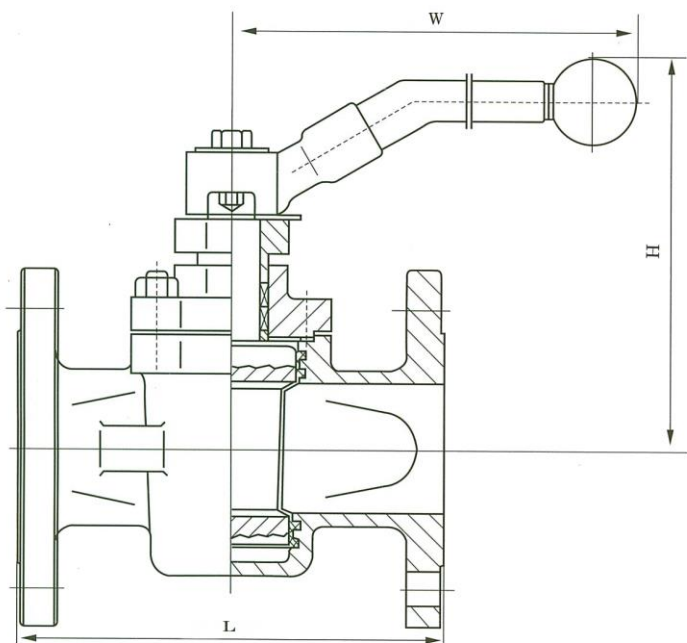

**L-RF (Lever Operated)**

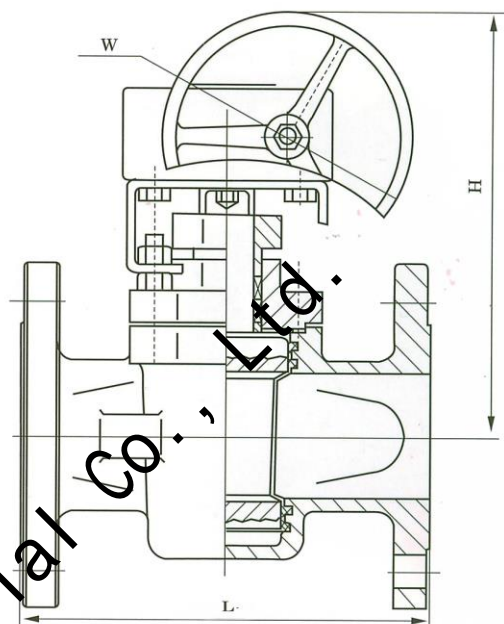

**L-RF (Gear Operated)**

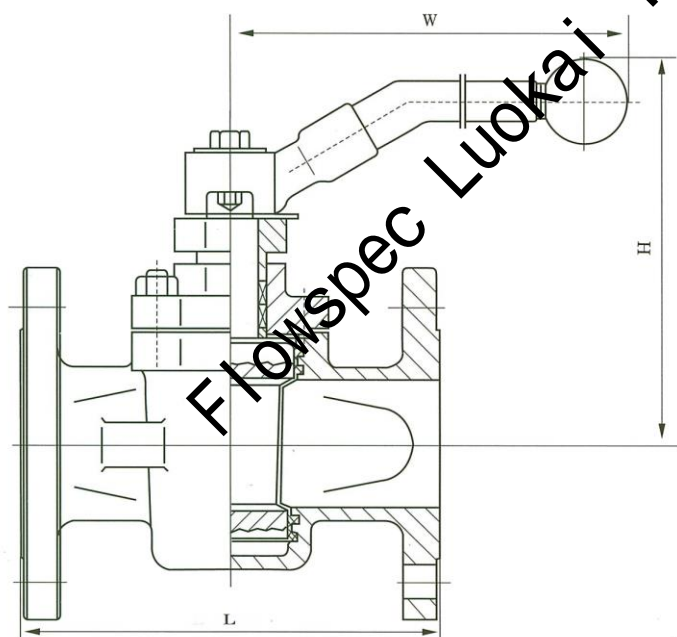

**L-RF (Lever Operated)**

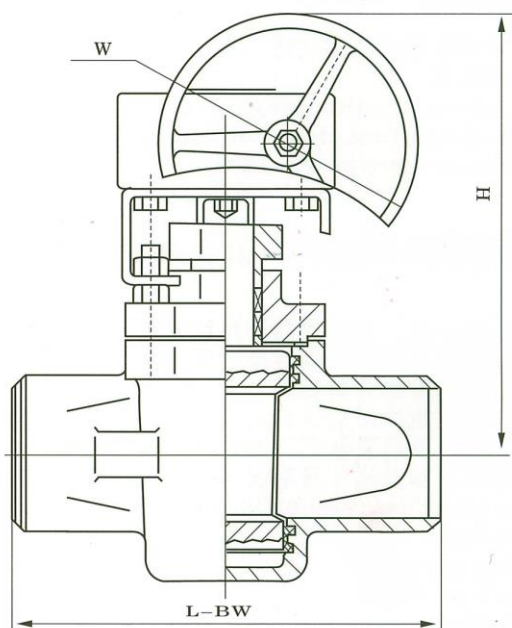

**L-BW (Gear Operated)**



**MAIN CONNECTION DIMENSIONS**

Model		X43F-150LB														
Pressure		150LB														
Size	mm	15	20	25	32	40	50	65	80	100	125	150	200	250	300	350
	in	1/2	3/4	1	1 1/4	1 1/2	2	2 1/2	3	4	5	6	8	10	12	14
L-RF		108	117	127	140	165	178	190	203	229	245	267	292	330	356	381
L-BW		152	178	203	216	229	267	305	330	356	381	394	457	533	610	686
H		110	115	115	135	140	150	165	180	380	460	520	580	260	680	760
W		175	175	175	220	280	305	350	405	300	300	320	320	350	380	450
Weight(kg)		8.5	9.5	10.0	12	14	22	22	26	40	60	70	130	219	381	570
Model		X343F-300LB														
Pressure		300LB														
Size	mm	15	20	25	32	40	50	65	80	100	125	150	200	250	300	350
	in	1/2	3/4	1	1 1/4	1 1/2	2	2 1/2	3	4	5	6	8	10	12	14
L-RF		108	117	127	140	165	178	190	203	229	245	267	292	330	356	381
L-BW		152	178	203	216	229	267	305	330	356	381	394	457	533	610	686
H		110	115	115	135	140	150	165	180	380	460	520	580	260	680	760
W		175	175	175	220	280	305	350	405	300	300	320	320	350	380	450
Weight(kg)		8.5	9.5	10.0	12	14	22	22	26	40	60	70	130	219	381	570
Model		X43F-600LB														
Pressure		600LB														
Size	mm	15	20	25	32	40	50	65	80	100	125	150	200	250	300	350
	in	1/2	3/4	1	1 1/4	1 1/2	2	2 1/2	3	4	5	6	8	10	12	14
L-RF.BW		165	190	216	229	214	292	330	356	432	508	559	660	787	838	889
H		110	115	115	135	140	150	165	180	380	460	520	580	260	680	760
W		175	175	175	220	280	305	350	405	300	300	320	320	350	380	450
Weight(kg)		11	13	17	20	23	27	31	36	72	98	141	245	330	515	710
Model		X343F-600LB														
Pressure		900LB														
Size	mm	15	20	25	32	40	50	65	80	100	125	150	200	250	300	350
	in	1/2	3/4	1	1 1/4	1 1/2	2	2 1/2	3	4	5	6	8	10	12	14
L-RF.BW		229	229	254	279	305	368	419	381	457	559	610	737	838	965	1029
H		110	115	115	135	140	150	165	180	380	460	520	580	260	680	760
W		175	175	175	220	280	305	350	405	300	300	320	320	350	380	450
Weight(kg)		13	16	21	24	28	32	40	47	91	117	165	285	420	610	860

Note: 4" or above with worm gear