



## UZ73X Bi-directional Seal Knife Gate Valve

**Model:** UZ73X-10  
**Working Pressure:** DN50-DN100 16bar  
 DN125-DN200 10bar  
 DN250-DN400 7bar  
 DN450-DN550 5bar  
 DN600-DN700 3bar  
 DN800-DN900 2bar  
 DN1000-DN1400 1bar

**Type:** Wafer  
**Design Standard:** MSS SP-81  
**Flange Standard:** DIN3202 PN10/PN16  
**Face to Face:** MSS SP-81  
**Testing Standard:** API-598

**Operation:** handwheel, electric, pneumatic, hydraulic, sprocket, electro-hydraulic, gear

**Main material:** F55, F53, 2205, CF3M, CF8M, CF8, WCB, GGG40

**Wedge material:** F55, F53, 2205, SS310, SS316L, SS316, SS304

**Sealing material:** NBR, EPDM

**Packing:** high-water-based rubber packing graphite wheel  
**Applicable medium:** coal in power plant, slag discharge, sewage treatment, food, paper making, medicine, petroleum and chemical industry, water, oil, steam, connecting or cutting grout, gold powder, ores, slag, coal, pulp, wood pulp, tailings, fibers, dust, chemicals, sewage treatment, sedimentation tanks, asphalt, bunker export, fruit juices, cereals, slaughter plant waste and other media.

### Features:

- # Bi-directional seal
- # 1PC body design
- # Full port design
- # Reduce fluid retention in valve body
- # 2PC strong yoke design
- # Mixed with a variety of materials packing

### Product Description:

UZ73X non groove bi-directional seal knife gate valve, cast iron body with the over all structure knife gate valve, including valve body, knife gate, and U-shaped flexible seal at the bottom of the body with grooves. When the valve is closed, the bottom of the gate edge contacts with the seal and then compress the seal into the groove in the body, achieving in the gate sealing; when the gate opens, separate gate from the bottom edge of the seal, seal will bounce to same level as groove, which will prevent the media sediment from being accumulated in the body cavity of the groove, with no clogging or no residue, pipe easy to clean, so as to effectively improve the sealing effects knife gate valve to prevent leakage when the valve is closed.

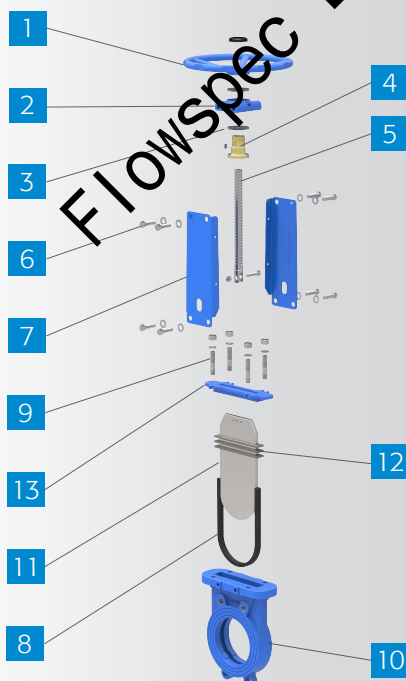

Code	Name	Material	QTY
1*	Hand wheel	Malleable Steel	1
2	Yoke Cap	WCB	1
3	Bearing	Gcr15	2
4	Stem Nut	Brass	1
5	Stem	2Cr13/SS304/SS316	1
6	Bolt & Nut	SS201/SS304	N
7	Yoke	Q235	2
8	Seat	EPDM/NBR/FKM	1
9	Bolt & Nut	SS201/SS304	N
10	Body	F55.F53.CF3M.CF8M.CF8.WCB.GGG40	1
11	Disc	F55/F53/SS304/SS316/2205	1
12	Packing	PTFE+EPDM	3-5
13	Packing Gland	CF8M/CF8/WCB/GGG40	1

\*electric, pneumatic, hydraulic, sprocket, electro-hydraulic, gear **available**

## Dimension

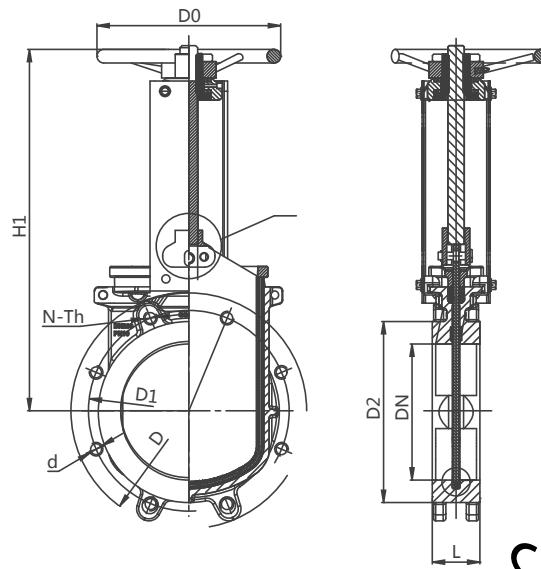

unit:mm

DIN2632 PN10										ANSI 150LB							
DN	L	D	D1	D2	D0	N-Th	d	H1	DN	L	D	D1	D2	D0	N-Th	d	H1
50	48	165	125	99	180	4-M16	Ø18	290	2-1/2"	48	152	121	92	180	4-5/8"	Ø19	260
65	48	185	145	118	200	4-M16	Ø18	350	3"	51	178	140	105	200	4-5/8"	Ø19	292
80	51	200	160	132	200	8-M16	Ø18	358	4"	51	229	191	157	240	8-5/8"	Ø19	358
100	51	220	180	156	240	8-M16	Ø18	378	5"	57	254	216	186	260	8-3/4"	Ø22	395
125	57	250	210	184	260	8-M16	Ø18	428	6"	57	279	242	216	280	8-3/4"	Ø22	450
150	57	285	240	211	280	8-M20	Ø23	490	8"	70	343	299	270	300	8-3/4"	Ø22	532
175	57	305	265	237	280	12-M20	Ø23	553	10"	70	406	362	324	320	12-7/8"	Ø25	670
200	70	340	295	266	300	8-M20	Ø23	588	12"	76	483	432	381	350	12-7/8"	Ø25	758
250	70	395	350	320	320	12-M20	Ø23	690	14"	76	533	476	413	400	12-1"	Ø29	857
300	76	445	400	370	350	12-M20	Ø23	815	16"	89	597	540	470	450	16-1"	Ø29	946
350	76	505	460	429	400	16-M20	Ø23	890	18"	89	635	578	533	500	16-1 1/8"	Ø32	1023
400	89	565	515	480	450	16-M24	Ø27	980	20"	114	699	635	584	500	20-1 1/8"	Ø32	Gear
450	89	615	565	530	500	20-M24	Ø27	1025	22"	114	750	692	641	-	20-1 1/4"	Ø35	Gear
500	114	670	620	582	500	20-M24	Ø27	1230	24"	114	813	750	691	-	20-1 1/4"	Ø35	Gear
550	114	725	680	638	-	20-M27	Ø30	1344	26"	114	870	806	749	-	24-1 1/4"	Ø35	Gear
600	114	780	725	682	-	20-M27	Ø30	1390	28"	127	927	864	800	-	28-1 1/4"	Ø35	Gear
700	127	895	840	794	-	24-M27	Ø30	1720	30"	127	985	914	857	-	28-1 1/4"	Ø35	Gear
800	127	1015	950	901	-	24-M30	Ø33	1862	32"	127	1060	978	914	-	28-1 1/2"	Ø41	Gear
900	127	1115	1050	1001	-	28-M30	Ø33	1910	34"	127	1110	1029	965	-	32-1 1/2"	Ø41	Gear
1000	149	1230	1160	1112	-	28-M33	Ø36	Gear	36"	127	1170	1086	1022	-	32-1 1/2"	Ø41	Gear
1100	149	1340	1260	1220	-	28-M33	Ø36	Gear	38"	149	1240	1149	1073	-	32-1 1/2"	Ø41	Gear
1200	156	1455	1380	1328	-	32-M36	Ø39	Gear	40"	149	1290	1200	1124	-	36-1 1/2"	Ø41	Gear
									42"	149	1345	1257	1194	-	36-1 1/2"	Ø41	Gear
									44"	149	1405	1314	1245	-	40-1 1/2"	Ø41	Gear
									46"	149	1455	1365	1295	-	40-1 1/2"	Ø41	Gear
									48"	156	1510	1422	1359	-	44-1 1/2"	Ø41	Gear
									50"	156	1570	1480	1410	-	44-1 3/4"	Ø51	Gear
									52"	156	1625	1537	1461	-	44-1 3/4"	Ø51	Gear
									54"	171	1685	1594	1511	-	44-1 3/4"	Ø51	Gear
									56"	171	1745	1651	1575	-	48-1 3/4"	Ø51	Gear

## PN10 Threaded hole and Tapping hole

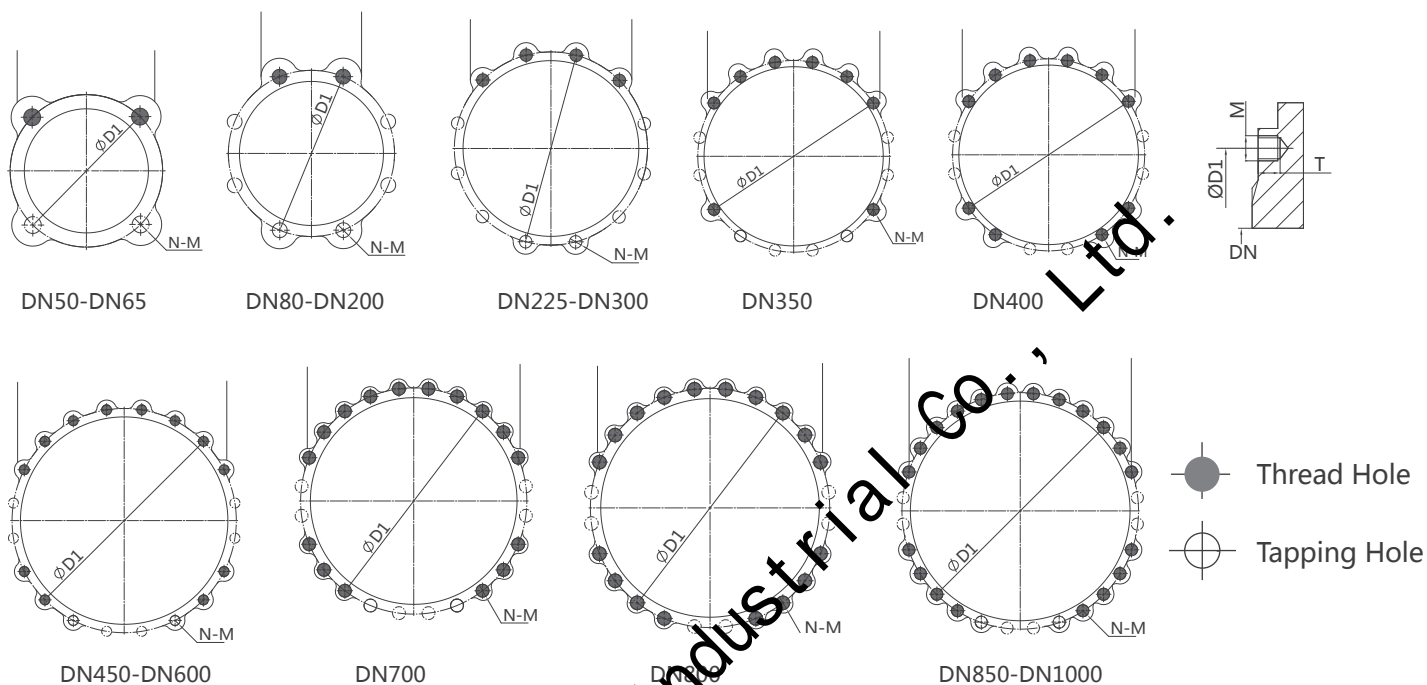

DN	D1	N	PN10		Thread Hole	Tapping Hole
			M	T		
50	125	4	M16	13	2	2
65	145	4	M16	13	2	2
80	160	8	M16	13	2	6
100	180	8	M16	13	2	6
125	210	8	M16	16	2	6
150	240	8	M16	16	2	6
200	295	8	M20	20	2	6
225	310	12	M20	20	4	8
250	350	12	M20	20	4	8
300	400	12	M20	20	4	8
350	460	16	M20	20	8	8
400	515	16	M24	24	10	6
450	565	20	M24	24	12	8
500	620	20	M24	24	12	8
550	680	20	M27	24	12	8
600	725	20	M27	27	12	8
700	840	24	M27	27	16	8
800	950	24	M30	30	18	6
900	1050	28	M30	30	20	8
1000	1160	28	M33	33	20	8

## 150LB Threaded hole and Tapping hole

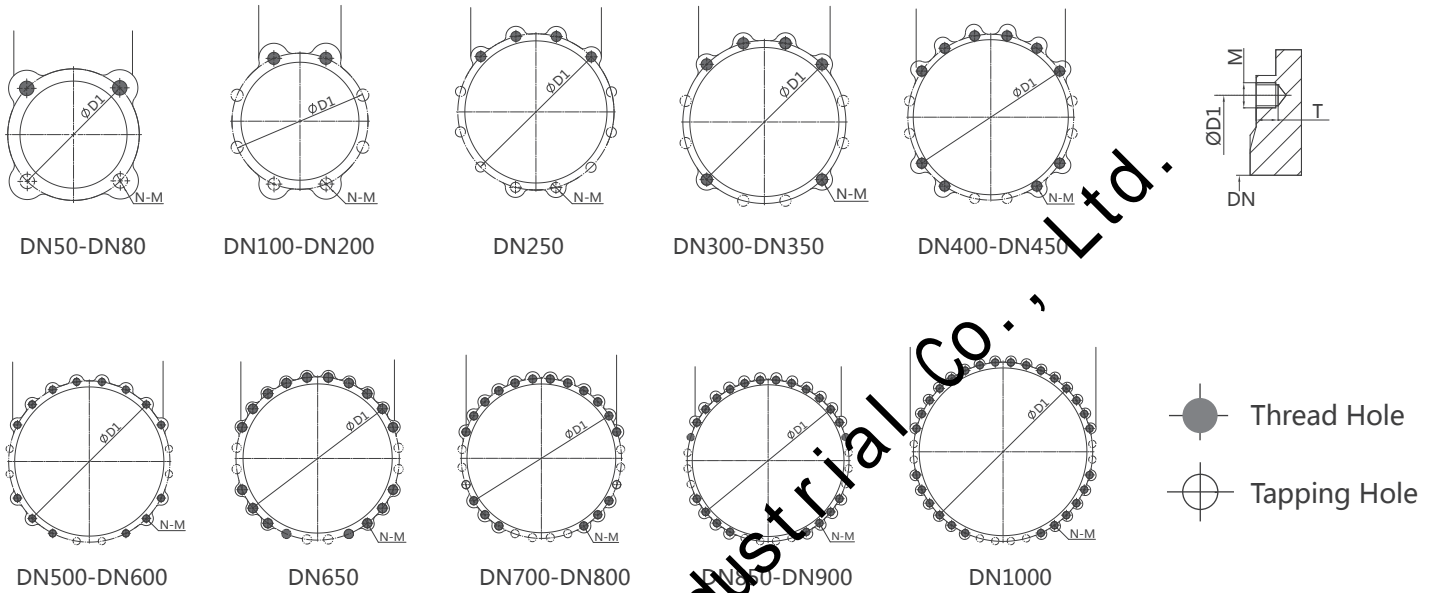

DN	D1	N	M	T	Thread Hole	Tapping Hole
2"(DN50)	121	4	M5/8-11	13	2	2
2-1/2"(DN65)	140	4	M5/8-11	13	2	2
3"(DN80)	153	4	M5/8-11	13	2	2
4"(DN100)	191	8	M5/8-11	13	2	6
5"(DN125)	216	8	M3/4-10	16	2	6
6"(DN150)	242	8	M3/4-10	16	2	6
8"(DN200)	289	8	M3/4-10	20	2	6
10"(DN250)	362	12	M7/8-9	20	4	8
12"(DN300)	432	12	M7/8-9	20	6	6
14"(DN350)	476	12	M1-8	20	6	6
16"(DN400)	540	16	M1-8	24	10	6
18"(DN450)	578	16	M1 1/8-7	24	10	6
20"(DN500)	635	20	M1 1/8-7	24	14	6
22"(DN550)	692	20	M1 1/4-7	24	14	6
24"(DN600)	750	20	M1 1/4-7	27	14	6
26"(DN650)	806	24	M1 1/4-7	27	18	6
28"(DN700)	864	28	M1 1/4-7	27	18	10
30"(DN750)	914	28	M1 1/4-7	27	18	10
32"(DN800)	978	28	M1 1/2-6	30	18	10
34"(DN850)	1029	32	M1 1/2-6	30	22	10
36"(DN900)	1086	32	M1 1/2-6	30	22	10
40"(DN1000)	1200	36	M1 1/2-6	33	28	8