

FLOWSPEC LUOKAI INDUSTRIAL CO., LTD.

DESIGN STANDARD/设计标准		JIS F 7363-1996	
TEST/检验		JIS F 7400-1996	
HYDRAULIC INSPECTION/压力试验			
TEST PRESSURE / 试验压力 Mpa	BODY / 强度	400 or less	1.05
		450	0.75
	SEAT / 密封	400 or less	0.77
		450	0.55

DN	d	L	D	C	NO.	h	t	H	D2
50	50	180	130	105	4	15	16	285	125
65	65	190	155	130	4	15	18	330	140
80	80	200	180	145	4	19	18	380	160
100	100	230	200	165	8	19	20	430	180
125	125	250	235	200	8	19	20	495	200
150	150	270	265	230	8	19	22	560	224
200	200	290	320	280	8	23	24	680	280
250	250	330	385	345	12	23	26	800	355
300	300	370	430	390	12	23	28	920	400
350	335	410	480	435	12	25	30	1000	450
400	380	470	540	495	16	25	30	1100	500

9	闸板	HT200		DISC	FC200	
8	手轮	HT200		HANDWHEEL	FC200	
7	垫片	非石棉		GASKET	non-asbestos	
6	压盖	ZCuSn5Pb5Zn5		packing gland	BC6	
5	阀杆	HPb59-1	1Cr12	STEM	C3771BD OR BE	SUS 403
4	阀座(闸板)	ZCuSn5Pb5Zn5	ZG2Cr13	VALVE SEAT	BC6	SCS2
3	阀座(阀体)	ZCuSn5Pb5Zn5	ZG2Cr13	VALVE SEAT	BC6	SCS2
2	阀盖	HT200		BONNET	FC200	
1	阀体	HT200		BODY	FC200	
序号	零件名称	CLASS B	CLASS S	NAME OF PART	CLASS B	CLASS S
		材料			MATERIAL	
铸铁闸阀 5K				Cast iron 5K gate valves		



Flowspec Industrial Limited

Luokai Industrial Co., Ltd.

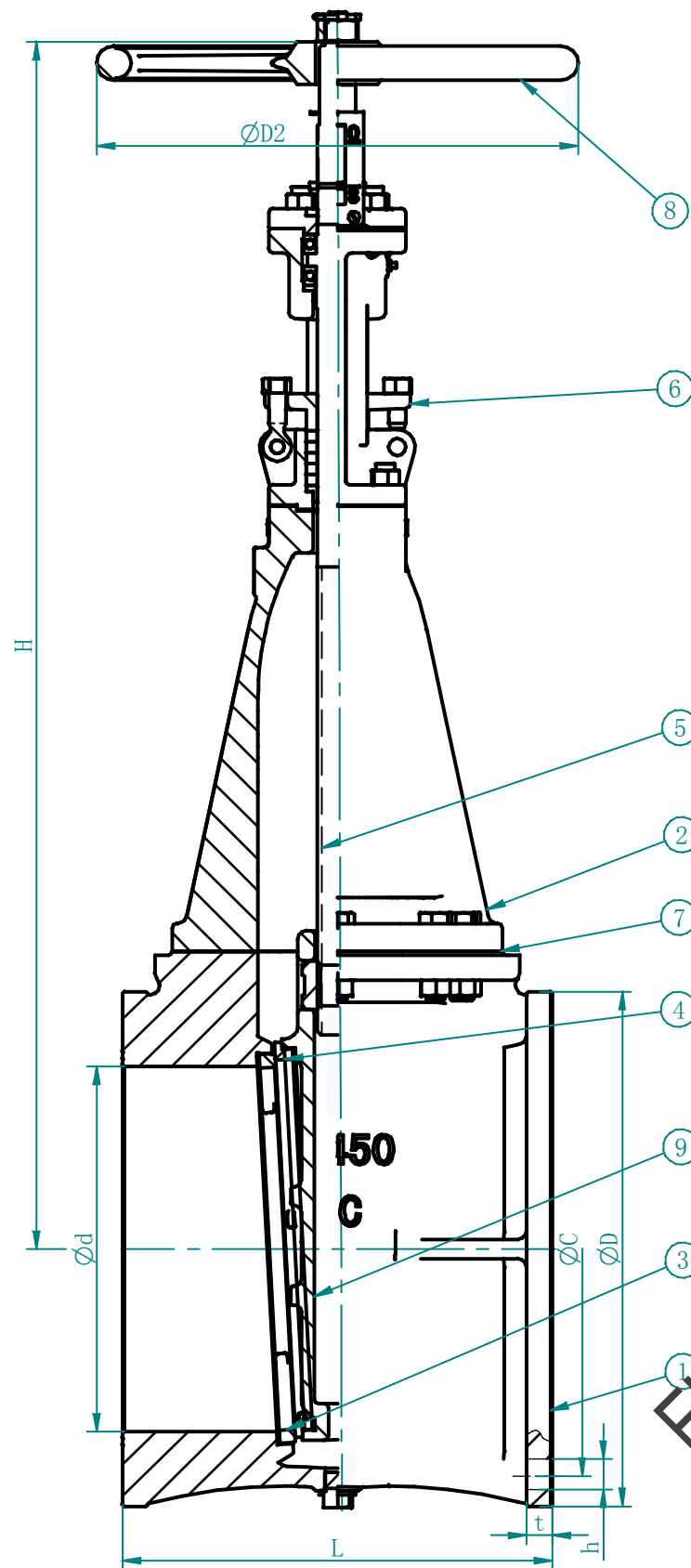

FLWSPEC LUOKAI INDUSTRIAL CO., LTD.

DESIGN STANDARD/设计标准		JIS F 7363-1996	
TEST/检验		JIS F 7400-1996	
HYDRAULIC INSPECTION/压力试验			
TEST PRESSURE / 试验压力 Mpa	BODY / 强度	400 OR LESS	1.05
		450	0.75
	SEAT / 密封	400 OR LESS	0.77
		450	0.55

9	闸板	HT200	DISC	FC200		
8	手轮	HT200	HANDWHEEL	FC200		
7	垫片	非石棉	GASKET	non-asbestos		
6	压盖	ZCuSn5Pb5Zn5	packing gland	BC6		
5	阀杆	HPb59-1	1Cr13	STEM	C3771BD OR BE	SUS 403
4	阀座(闸板)	ZCuSn5Pb5Zn5	ZG2Cr13	VALVE SEAT	BC6	SCS2
3	阀座(阀体)	ZCuSn5Pb5Zn5	ZG2Cr13	VALVE SEAT	BC6	SCS2
2	阀盖	HT200	BONNET	FC200		
1	阀体	HT200	BODY	FC200		
序号	零件名称	CLASS B	CLASS S	NAME OF PART	CLASS B	CLASS S
		材料			MATERIAL	
铸铁闸阀 5K				Cast iron 5K gate valves		

DN	d	L	D	C	NO.	h	t	H	D2
450	430	500	605	555	16	25	30	1420	560



Flowspec Industrial Limited

Luokai Industrial Co., Ltd.