

For nominal dia. 250 to 300

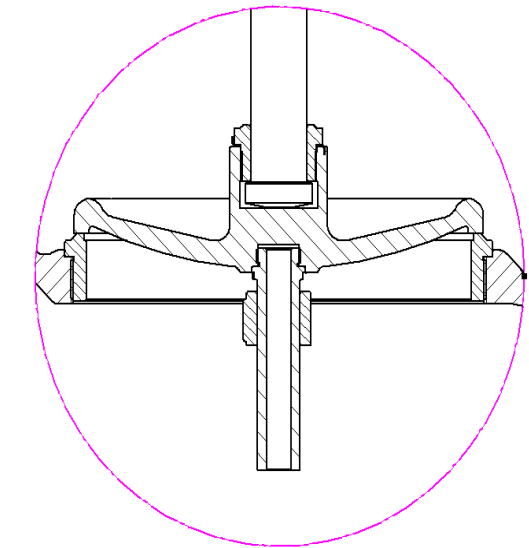
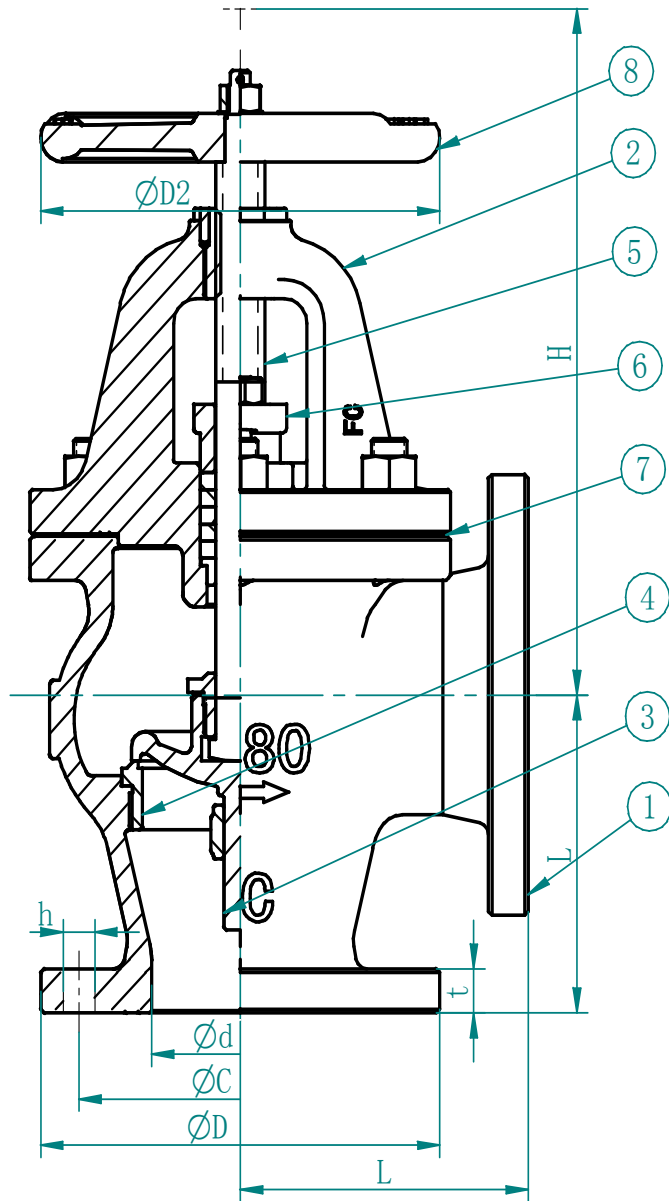

DESIGN STANDARD/设计标准		JIS F 7308-1996	
TEST/检验		JIS F 7400-1996	
HYDRAULIC INSPECTION/压力试验			
TEST PRESSURE / 试验压力 Mpa	BODY / 强度	200 or less	2.1
		250 or more	1.5
	SEAT / 密封	200 or less	1.54
		250 or more	1.1
MEDIUM: WATER, AIR, GAS, OIL, STEAM			
TEMPERATURE: ≤205°C			

DN	d	L	D	C	NO.	h	t	H	D2
50	50	120	155	120	4	19	20	255	160
65	65	130	175	140	4	19	22	270	200
80	80	140	185	150	8	19	22	275	200
100	100	160	210	175	8	19	24	315	250
125	125	180	250	210	8	23	24	360	280
150	150	205	280	240	8	23	26	405	315
200	200	230	330	290	12	23	26	475	355
250	250	290	400	355	12	25	30	570	450
300	300	320	445	400	16	25	32	645	500

8	手轮	HT200		HANDWHEEL	FC200	
7	垫片	非石棉		GASKET	non-asbestos	
6	压盖	ZCuSn5Pb5Zn5		packing gland	BC6	
5	阀杆	HPb59-1	1Cr12	STEM	C3771BD OR BE	SUS 403
4	阀座	ZCuSn5Pb5Zn5	ZG2Cr13	VALVE SEAT	BC6	SCS2
3	阀盘	ZCuSn5Pb5Zn5	ZG2Cr13	DISC	BC6	SCS2
2	阀盖	HT200		BONNET	FC200	
1	阀体	HT200		BODY	FC200	
序号	零件名称	CLASS B	CLASS S	NAME OF PART	CLASS B	CLASS S
		材料			MATERIAL	
铸铁角式截止阀 10K				Cast iron 10K Angle valves		



**Flowspec Industrial Limited**

**Luokai Industrial Co., Ltd.**