

For nominal dia. 250 to 300

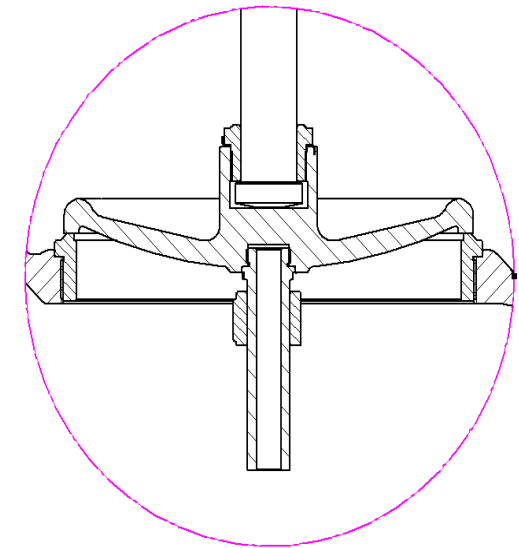
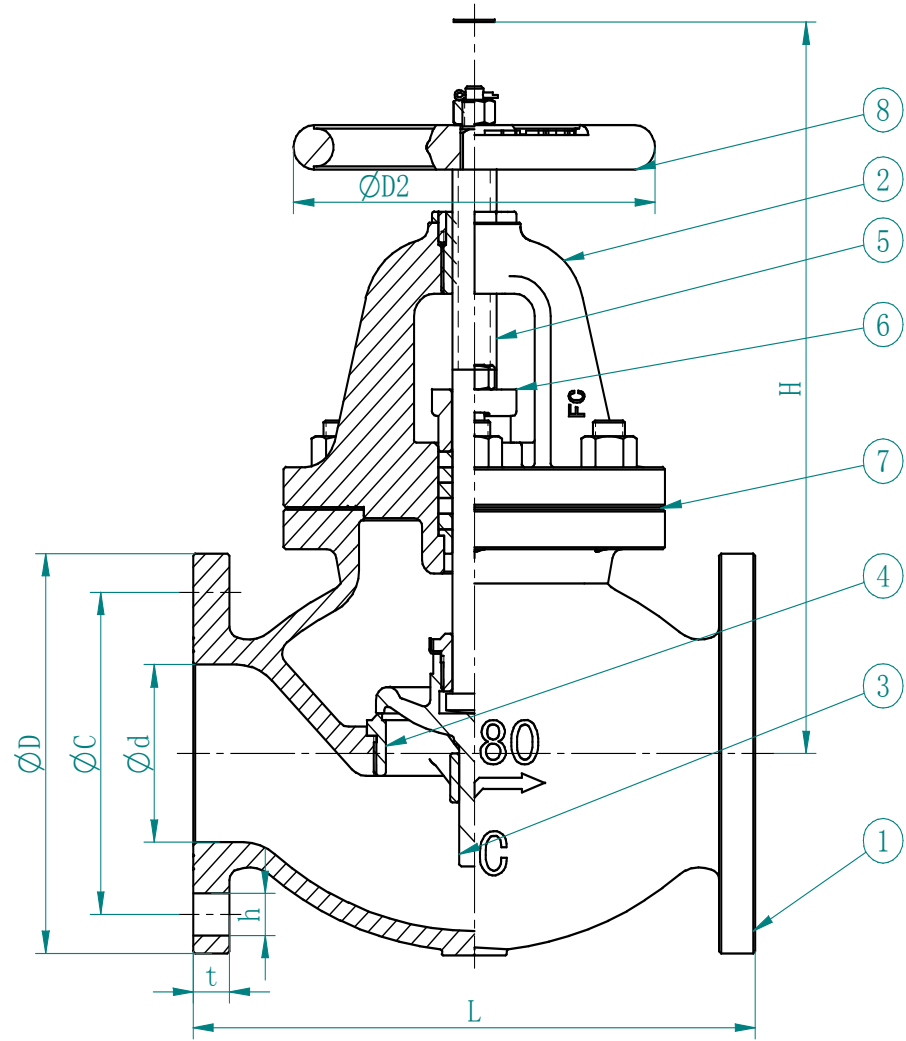

DESIGN STANDARD/设计标准		JIS F 7307-1996	
TEST/检验		JIS F 7400-1996	
HYDRAULIC INSPECTION/压力试验			
TEST PRESSURE / 试验压力 Mpa	BODY / 强度	200 or less	2.1
		250 or more	1.5
	SEAT / 密封	200 or less	1.54
		250 or more	1.1
MEDIUM: WATER, AIR, GAS, OIL, STEAM			
TEMPERATURE: ≤205°C			

FLOWSPEC LUOKAI INDUSTRIAL CO., LTD.

DN	d	L	D	C	NO.	h	t	H	D2
50	50	220	155	120	4	19	20	285	160
65	65	270	175	140	4	19	22	310	200
80	80	300	185	150	8	19	22	320	200
100	100	350	210	175	8	19	24	370	250
125	125	420	250	210	8	23	24	420	280
150	150	490	280	240	8	23	26	470	315
200	200	570	330	290	12	23	26	555	355
250	250	740	400	355	12	25	30	680	470
300	300	840	445	400	16	25	32	770	550

8	手轮	HT200		HANDWHEEL	FC200	
7	垫片	非石棉		GASKET	non-asbestos	
6	压盖	ZCuSn5Pb5Zn5		packing gland	BC6	
5	阀杆	HPb59-1	1Cr12	STEM	C3771BD OR BE	SUS 403
4	阀座	ZCuSn5Pb5Zn5	ZG2Cr13	VALVE SEAT	BC6	SCS2
3	阀盘	ZCuSn5Pb5Zn5	ZG2Cr13	DISC	BC6	SCS2
2	阀盖	HT200		BONNET	FC200	
1	阀体	HT200		BODY	FC200	
序号	零件名称	CLASS B	CLASS S	NAME OF PART	CLASS B	CLASS S
		材料			MATERIAL	
铸铁球形截止阀 10K				Cast iron 10K globe valves		

Flowspec Industrial Limited

Luokai Industrial Co., Ltd.

FLWSPEC LUOKAI INDUSTRIAL CO., LTD.