

For nominal dia. 250 to 350

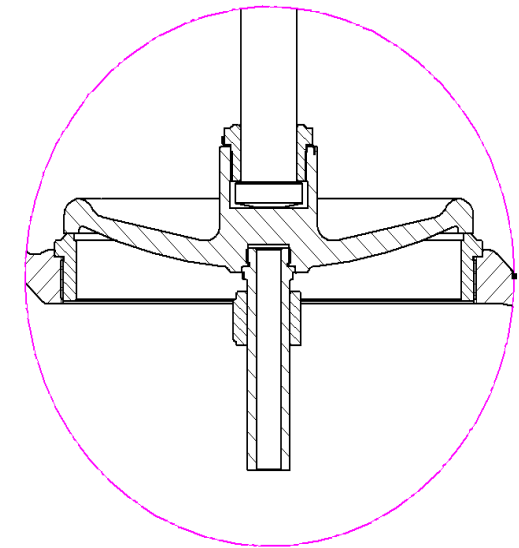
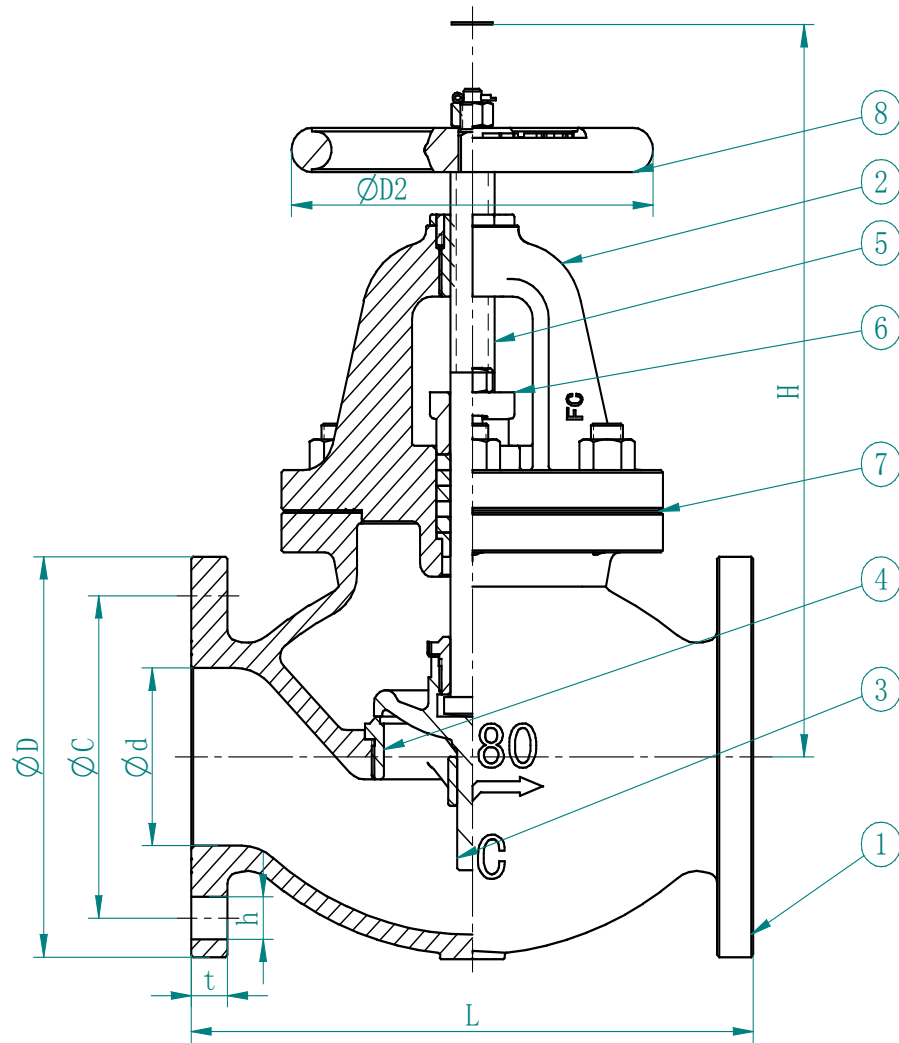

DESIGN STANDARD/设计标准		JIS F 7305-1996	
TEST/检验		JIS F 7400-1996	
HYDRAULIC INSPECTION/压力试验			
TEST PRESSURE / 试验压力 Mpa	BODY / 强度	300 OR LESS	1.05
		350	0.9
	SEAT / 密封	300 OR LESS	0.77
		350	0.66
MEDIUM: WATER, AIR, GAS, OIL, STEAM			
TEMPERATURE: ≤205°C			

FLAWSPEC LUOKAI INDUSTRIAL CO., LTD.

DN	d	L	D	C	NO.	h	t	H	D2
50	50	210	130	105	4	15	16	270	160
65	65	250	155	130	4	15	18	300	180
80	80	280	180	145	4	19	18	310	180
100	100	340	200	165	8	19	20	360	224
125	125	410	235	200	8	19	20	390	250
150	150	480	265	230	8	19	22	445	280
200	200	570	320	280	12	23	24	530	315
250	250	740	385	345	12	23	26	650	355
300	300	840	430	390	12	23	28	740	400
350	335	940	480	435	12	25	30	840	500
400	380	1050	540	495	16	25	30	940	560

序号	零件名称	CLASS B	CLASS S	NAME OF PART	CLASS B	CLASS S
		材料		MATERIAL		
8	手轮	HT200		HANDWHEEL	FC200	
7	垫片	非石棉		GASKET	non-asbestos	
6	压盖	ZCuSn5Pb5Zn5		packing gland	BC6	
5	阀杆	HPb59-1	1Cr12	STEM	C3771BD OR BE	SUS 403
4	阀座	ZCuSn5Pb5Zn5	ZG2Cr13	VALVE SEAT	BC6	SCS2
3	阀盘	ZCuSn5Pb5Zn5	ZG2Cr13	DISC	BC6	SCS2
2	阀盖	HT200		BONNET	FC200	
1	阀体	HT200		BODY	FC200	
		铸铁球形截止阀 5K		Cast iron 5K globe valves		



Flowspec Industrial Limited

Luokai Industrial Co., Ltd.