

PRESSURE SEAL CAST STEEL GATE VALVE 900Lb

Applicable standards:

STEEL GATE VALVES, API 600/API 6D
 STEEL GATE VALVES, ISO 10434/ISO 14313
 STEEL VALVES, ASME B 16.34
 FACE TO FACE, ASME B 16.10
 END FLANGES, ASME B 16.5
 BUTTWELDING ENDS, ASME B 16.25
 INSPECTION AND TEST, API 598/API 6D

Design description:

PSB, PRESSURE SEAL BONNET
 FLEXIBLE WEDGE, FULLY GUIDED
 CHOICE OF SOLID OR SPLIT WEDGE
 RENEWABLE SEAT RINGS
 FORGED T-HEAD STEM
 RISING STEM AND NON-RISING HANDWHEEL
 FLANGED OR BUTTWELDING ENDS
 AVAILABLE WITH BG OPERATOR

Materials of parts

No	Part Name	Carbon Steel	ASTM Material 1 ¹ / ₄ Cr- ¹ / ₂ Mo	18Cr-9Ni-2Mo
1	Body	A216-WCB	A217-WC6	A351-CF8M
2	Yoke	A216-WCB	A217-WC6	A351-CF8M
3	Wedge	A216-WCB+HF	A217-WC6+HF	A351-CF8M+HF
4	Stem	A182-F6a	CR-MO-V	A182-316
5	Seat Ring	A105+HF	A182-F11+HF	A240-316+HF
6	Bonnet	A105	A182-F11	A240-316
7	Bonnet Gasket ¹⁾		304+Graphite	
8	Adapter Ring	Carbon Steel	A276-420	A276-316
9	Retainer	Carbon Steel	A276-420	A276-316
10	Yoke Cap	Carbon Steel	Alloy Steel	Stainless Steel
11	Bonnet Stud	A193-B7	A193-B16	A193-B8M
12	Bonnet Stud Nut	A194-2H	A194-7	A194-8M
13	Packing		Graphite	
14	Gland	A276-420	A276-304	A276-316L
15	Gland Flange	A216-WCB	A217-WC6	A351-CF8M
16	Eyebolt Pin	Carbon Steel	A276-420	A276-316
17	Eyebolt	Carbon Steel	A193-B7	A193-B8
18	Eyebolt Nut	Carbon Steel	A194-2H	A194-8
19	Grease Fitting		Brass+Steel	
20	Yokesleeve		Aluminum-Bronze ²⁾	
21	Yokesleeve Jam Nut	Carbon Steel		
22	Handwheel		Malleable Iron	
23	Handwheel Nut		Carbon Steel	

Note: 1). Graphite optional
 2). Ductile Ni-Resist optional
 3). Wedge and seat ring material either be solid facing material or a base material equal to or better than the body/bonnet material with facing as shown.

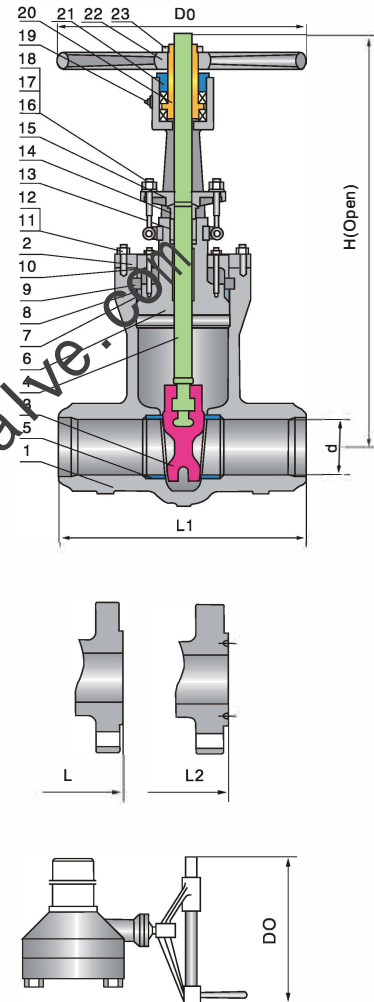

Dimensions data

NPS	2	2 1/2	3	4	6	8	10	12	14	16	18	20	24	26	28	32	34	36	in
DN	50	65	80	100	150	200	250	300	350	400	450	500	600	650	700	800	850	900	mm
ANSI Class 900Lb																			
L1 (BW)	8.50	10.00	12.00	14.00	20.00	26.00	31.00	36.00	39.00	43.00	47.99	52.00	60.98	61.96	65.47	70.00	72.99	80.00	in
	216	254	305	356	508	660	787	914	991	1092	1219	1321	1549	1574	1663	1778	1854	2032	mm
L (RF)	14.50	16.50	15.00	18.00	24.00	29.00	33.00	38.00	40.50	44.50	47.99	52.00	60.98	61.96	65.47	70.00	72.99	80.00	in
	368	419	381	457	610	737	838	965	1029	1130	1219	1321	1549	1574	1663	1778	1854	2032	mm
L2 (RTJ)	14.62	16.62	15.12	18.12	24.12	29.12	33.12	38.12	40.88	44.88	48.50	52.51	61.73	-	-	-	-	-	in
	371	422	384	460	613	740	841	968	1038	1140	1232	1334	1568	-	-	-	-	-	mm
H (OPEN)	17.62	17.62	19.5	22.88	32.62	67.62	53.12	59	70.5	93.74	96.49	116.96	131.96	145.47	157.48	163.97	180.98	in	
	448	448	495	580	830	955	1155	1350	1500	1790	2381	2451	2971	3352	3695	4000	4165	4597	mm
D0	14	14	14	14	18	24	28	34	34	34	29.92	29.92	35.43	35.43	35.43	35.43	35.43	35.43	in
	350	350	350	350	450	600	700	850	850	850	760	760	900	900	900	900	900	900	mm
WT (kg)	39	39	48	69	158	289	482	710	998	1390	2340	2800	3420	4270	5454	7392	9042	10874	BW
	69	69	72	110	253	430	710	1025	1452	1960	2750	3400	4400	5500	6900	9000	11000	13500	RF/RT

PRESSURE SEAL CAST STEEL GATE VALVE 1500lb

Applicable standards:

STEEL GATE VALVES, API 600/API 6D
 STEEL GATE VALVES, ISO 10434/ISO 14313
 STEEL VALVES, ASME B 16.34
 FACE TO FACE, ASME B 16.10
 END FLANGES, ASME B 16.5
 BUTTWELDING ENDS, ASME B 16.25
 INSPECTION AND TEST, API 598/API 6D

Design description:

PSB, PRESSURE SEAL BONNET
 FLEXIBLE WEDGE, FULLY GUIDED
 CHOICE OF SOLID OR SPLIT WEDGE
 RENEWABLE SEAT RINGS
 FORGED T-HEAD STEM
 RISING STEM AND NON-RISING HANDWHEEL
 FLANGED OR BUTTWELDING ENDS
 AVAILABLE WITH BG OPERATOR

Materials of parts

No	Part Name	Carbon Steel	ASTM Material 1 ¹ / ₄ Cr- ¹ / ₂ Mo	18Cr-9Ni-2Mo
1	Body	A216-WCB	A217-WC6	A351-CF8M
2	Yoke	A216-WCB	A217-WC6	A351-CF8M
3	Wedge	A216-WCB+HF	A217-WC6+HF	A351-CF8M+HF
4	Stem	A182-F6a	CR-MO-V	A182-316
5	Seat Ring	A105+HF	A182-F11+HF	A240-316+HF
6	Bonnet	A105	A182-F11	A240-316
7	Bonnet Gasket ¹⁾		304+Graphite	
8	Adapter Ring	Carbon Steel	A276-420	A276-316
9	Retainer	Carbon Steel	A276-420	A276-316
10	Yoke Cap	Carbon Steel	Alloy Steel	Stainless Steel
11	Bonnet Stud	A193-B7	A193-B16	A193-B8M
12	Bonnet Stud Nut	A194-2H	A194-7	A194-8M
13	Packing		Graphite	
14	Gland	A276-420	A276-304	A276-316L
15	Gland Flange	A216-WCB	A217-WC6	A351-CF8M
16	Eyebolt Pin	Carbon Steel	A276-420	A276-316
17	Eyebolt	Carbon Steel	A193-B7	A193-B8
18	Eyebolt Nut	Carbon Steel	A194-2H	A194-8
19	Grease Fitting		Brass+Steel	
20	Yokesleeve		Aluminum-Bronze ²⁾	
21	Yokesleeve Jam Nut		Carbon Steel	
22	Handwheel		Malleable Iron	
23	Handwheel Nut		Carbon Steel	

Note: 1). Graphite optional
 2). Ductile Ni-Resist optional
 3). Wedge and seat ring may either be solid facing material or a base material equal to or better than the body/bonnet material with facing as shown.

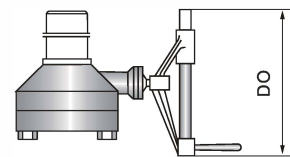
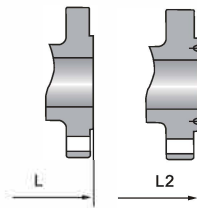
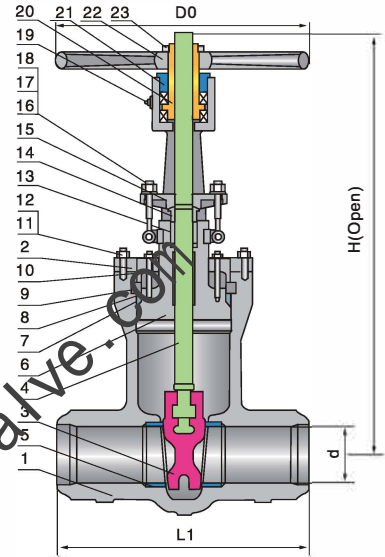

Dimensions data

NPS	2	2 ¹ / ₂	3	4	6	8	10	12	14	16	18	20	24	26	28	32	34	36	in
DN	50	65	80	100	150	200	250	300	350	400	450	500	600	650	700	800	850	900	mm

ANSI Class 1500Lb

L1 (BW)	8.50	10.00	12.00	16.00	22.00	28.00	34.00	39.00	42.00	47.00	52.99	57.99	76.49	80.00	86.96	90.00	95.00	100.98	in
	216	254	305	406	559	711	864	991	1067	1194	1346	1473	1943	2033	2209	2286	2413	2565	mm
L (RF)	14.50	16.50	18.50	21.50	27.75	32.75	39.00	44.50	49.50	54.50	60.51	65.51	76.49	80.00	86.96	90.00	95.00	100.98	in
	368	419	470	546	705	832	991	1130	1257	1384	1537	1664	1943	2033	2209	2286	2413	2565	mm
L2 (RTJ)	14.62	16.62	18.62	21.62	28.00	33.12	39.38	45.12	50.25	55.38	61.37	66.37	77.63	-	-	-	-	-	in
	371	422	473	549	711	841	1000	1146	1276	1407	1559	1686	1972	-	-	-	-	-	mm
H (OPEN)	17.62	17.62	21.62	25.25	33.5	38.62	46.5	62.25	70.5	78	86.96	93.97	110.00	121.96	133.97	147.48	120.00	127.99	in
	448	448	550	640	850	980	1180	1580	1790	1980	2209	2387	2794	3098	3403	3746	3048	3251	mm
D0	14	14	14	18	24	28	34	34	34	34	33.85	33.85	33.85	40.15	40.15	40.15	-	-	in
	350	350	350	450	600	700	850	850	850	850	860	860	860	1020	1020	1020	-	-	mm
WT (kg)	39	45	55	77	175	323	540	795	1115	1556	4000	4800	7500	8900	10000	13500	16000	18900	BW
	69	80	95	123	283	481	795	1148	1626	2195	5225	6310	9050	9934	11174	14852	17443	21246	RF/RTJ

PRESSURE SEAL CAST STEEL GATE VALVE 2500lb

Applicable standards:

STEEL GATE VALVES, API 600/API 6D
 STEEL GATE VALVES, ISO 10434/ISO 14313
 STEEL VALVES, ASME B 16.34
 FACE TO FACE, ASME B 16.10
 END FLANGES, ASME B 16.5
 BUTTWELDING ENDS, ASME B 16.25
 INSPECTION AND TEST, API 598/API 6D

Design description:

PSB, PRESSURE SEAL BONNET
 FLEXIBLE WEDGE, FULLY GUIDED
 CHOICE OF SOLID OR SPLIT WEDGE
 RENEWABLE SEAT RINGS
 FORGED T-HEAD STEM
 RISING STEM AND NON-RISING HANDWHEEL
 FLANGED OR BUTTWELDING ENDS
 AVAILABLE WITH BG OPERATOR

Materials of parts

No	Part Name	Carbon Steel	ASTM Material 1 1/4Cr-1/2Mo	18Cr-9Ni-2Mo
1	Body	A216-WCB	A217-WC6	A351-CF8M
2	Yoke	A216-WCB	A217-WC6	A351-CF8M
3	Wedge	A216-WCB+HF	A217-WC6+HF	A351-CF8M+HF
4	Stem	A182-F6a	CR-MO-V	A182-316
5	Seat Ring	A105+HF	A182-F11+HF	A240-316+HF
6	Bonnet	A105	A182-F11	A240-316
7	Bonnet Gasket ¹⁾		304+Graphite	
8	Adapter Ring	Carbon Steel	A276-420	A276-316
9	Retainer	Carbon Steel	A276-420	A276-316
10	Yoke Cap	Carbon Steel	Alloy Steel	Stainless Steel
11	Bonnet Stud	A193-B7	A193-B16	A193-B8M
12	Bonnet Stud Nut	A194-2H	A194-7	A194-8M
13	Packing		Graphite	
14	Gland	A276-420	A276-304	A276-316L
15	Gland Flange	A216-WCB	A217-WC6	A351-CF8M
16	Eyebolt Pin	Carbon Steel	A276-420	A276-316
17	Eyebolt	Carbon Steel	A193-B7	A193-B8
18	Eyebolt Nut	Carbon Steel	A194-2H	A194-8
19	Grease Fitting		Brass+Steel	
20	Yokesleeve		Aluminum-Bronze ²⁾	
21	Yokesleeve Jam Nut		Carbon Steel	
22	Handwheel		Malleable Iron	
23	Handwheel Nut		Carbon Steel	

Note: 1).Graphite optional
 2).Ductile Ni-Resist optional
 3).Wedge and seat ring may either be solid facing material or a base material equal to or better than the body/bonnet material with facing as shown.

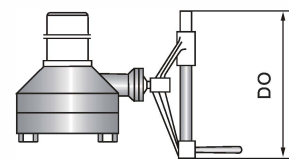
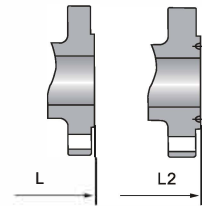
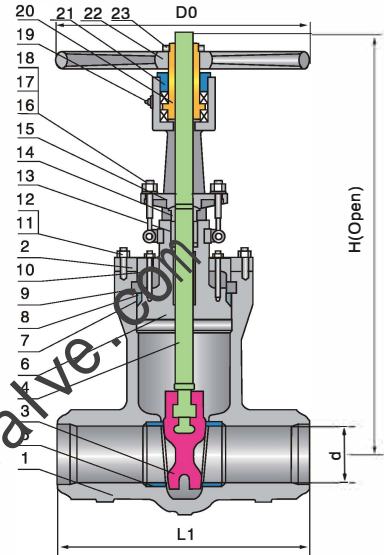

Dimensions data

NPS	2	2 1/2	3	4	6	8	10	12	14	16	18	20	24	26	28	32	34	36	in
DN	50	65	80	100	150	200	250	300	350	400	450	500	600	650	700	800	850	900	mm

ANSI Class 2500Lb

	11.00	13.00	14.50	18.00	24.00	30.00	36.00	41.00	44.01	49.01	55.00	55.00	63.97	70.00	75.00	80.00	85.98	95.00	in
L1 (BW)	279	330	368	457	610	762	914	1041	1118	1245	1397	1397	1625	1778	1905	2032	2184	2413	mm
L (RF)	17.75	20.00	22.75	26.50	36.00	40.25	50.00	56.00	-	-	-	-	-	-	-	-	-	-	in
L2 (RTJ)	17.88	20.50	23.00	26.88	36.50	40.88	50.88	56.88	-	-	-	-	-	-	-	-	-	-	in
H (OPEN)	22.5	22.5	25.62	30	36.62	41.38	44.88	60.25	54.29	58.30	65.00	71.29	75.00	80.00	82.99	92.99	96.96	120.59	in
D0	14	14	18	24	28	34	34	34	40.15	40.15	40.15	40.15	-	-	-	-	-	-	in
WT (kg)	110	110	150	175	380	575	980	1570	3200	4100	5200	6800	9500	11000	13100	17200	19300	25000	BW
	165	195	235	316	635	910	1780	2680	-	-	-	-	-	-	-	-	-	-	RF/RTJ