

PRESSURE SEAL CAST STEEL GLOBE VALVE 900Lb

Applicable standards:

STEEL GLOBE VALVES, BS BS1873/API600
 STEEL VALVES, ASME B16.34
 FACE TO FACE, ASME B16.10
 END FLANGES, ASME B16.5
 BUTTWELDING ENDS, ASME B16.25
 INSPECTION AND TEST, API 598

Design description:

STRAIGHT PATTERN BODY DESIGN
 OS & Y, OUTSIDE SCREW AND YOKE
 PSB, PRESSURE SEAL BONNET
 YOKE INTEGRAL WITH BONNET
 RISING STEM AND HANDWHEEL
 LOOSE DISC, CHOICE OF PLUG OR BALL
 RENEWABLE SEAT RING
 IMPACT HANDWHEEL FOR 10" & ABOVE
 HORIZONTAL SERVICE
 FLANGED OR BUTTWELDING ENDS
 AVAILABLE WITH BG OPERATOR

Materials of parts

NO	Part Name	ASTM Material		
		Carbon Steel	1¼Cr-½Mo	18Cr-9Ni-2Mo
1	Body	A216-WCB	A217-WC6	A351-CF8M
2	Yoke	A216-WCB	A217-WC6	A351-CF8M
3	Disc	A216-WCB+HF	A217-WC6+HF	A351-CF8M+HF
4	Stem	A182-F6a	CR-MO-V	A182-316
5	Seat Ring	A105+HF	A182-F11+HF	A240-316+HF
6	Bonnet	A105	A182-F11	A240-316
7	Bonnet Gasket ⁽¹⁾		304+Graphite	
8	Adapter Ring	Carbon Steel	A276-420	A276-316
9	Packing		Graphite	
10	Eyebolt Pin	Carbon Steel	A276-420	A276-316
11	Eyebolt	Carbon Steel	A193-B7	A193-B8
12	Eyebolt Nut	Carbon Steel	A194-2H	A194-8
13	Locking Nut	Carbon Steel	Alloy Steel	Stainless Steel
14	Gland	A276-420	A276-304	A276-316
15	Gland Flange	A216-WCB	A217-WC6	A351-CF8M
16	Washer		Carbon Steel	
17	Stem Nut		Aluminum-Bronze ⁽²⁾	
18	Bolt		Carbon Steel	
19	Handwheel		Malleable Iron	
20	Handwheel Washer		Carbon Steel	
21	Handwheel Nut		A194-2H	

Note: 1) Graphite optional
 2) Ductile Ni-Resist optional
 3) Wedge and seat ring may either be solid facing material or a base material equal to or better than the body/bonnet material with facing as shown.

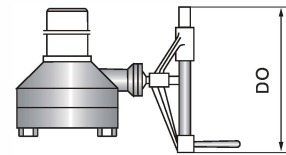
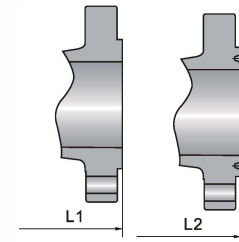
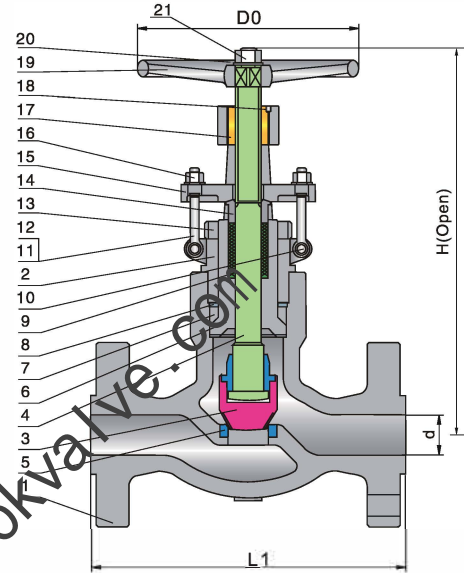

Dimensions data

NPS DN	2 50	2½ 65	3 80	4 100	6 150	8 200	10 250	12 300	in mm
-----------	---------	----------	---------	----------	----------	----------	-----------	-----------	----------

ANSI Class 900Lb

L1 (BW)	8.50 216	10.00 254	12.00 305	14.00 356	20.00 508	26.00 660	31.00 787	36.00 914	in mm
L (RF)	14.50 368	16.50 419	15.00 381	18.00 457	24.00 610	29.00 737	33.00 838	38.00 965	in mm
L2 (RTJ)	14.62 371	16.62 422	15.12 384	18.12 460	24.12 613	29.12 740	33.12 841	38.12 968	in mm
H (OPEN)	22 557	22 557	22 557	27 685	36.38 925	43.38 1100	50.62 1285	57 1450	in mm
D0	16 400	16 400	16 400	16 400	28 700	28 700	36 900	36 900	in mm
WT (kg)	46 75	53 82	68 95	100 135	270 355	450 680	740 1050	1150 1480	BW RTJ

PRESSURE SEAL CAST STEEL GLOBE VALVE 1500lb/2500lb

Applicable standards:

STEEL GLOBE VALVES, BS BS1873/API600
 STEEL VALVES, ASME B16.34
 FACE TO FACE, ASME B16.10
 END FLANGES, ASME B16.5
 BUTTWELDING ENDS, ASME B16.25
 INSPECTION AND TEST, API 598

Design description:

STRAIGHT PATTERN BODY DESIGN
 OS & Y, OUTSIDE SCREW AND YOKE
 PSB, PRESSURE SEAL BONNET
 YOKE INTEGRAL WITH BONNET
 RISING STEM AND HANDWHEEL
 LOOSE DISC, CHOICE OF PLUG OR BALL
 RENEWABLE SEAT RING
 IMPACT HANDWHEEL FOR 10" & ABOVE
 HORIZONTAL SERVICE
 FLANGED OR BUTTWELDING ENDS
 AVAILABLE WITH BG OPERATOR

Materials of parts

NO	Part Name	ASTM Material		
		Carbon Steel	1 $\frac{1}{4}$ Cr-1 $\frac{1}{2}$ Mo	18Cr-9Ni-2Mo
1	Body	A216-WCB	A217-WC6	A351-CF8M
2	Yoke	A216-WCB	A217-WC6	A351-CF8M
3	Disc	A216-WCB+HF	A217-WC6+HF	A351-CF8M+HF
4	Stem	A182-F6a	CR-MO-V	A182-316
5	Seat Ring	A105+HF	A182-F11+HF	A240-316+HF
6	Bonnet	A105	A182-F11	A240-316
7	Bonnet Gasket ¹⁾		304+Graphite	
8	Adapter Ring	Carbon Steel	A276-420	A276-316
9	Packing		Graphite	
10	Eyebolt Pin	Carbon Steel	A276-420	A276-316
11	Eyebolt	Carbon Steel	A193-B7	A193-B8
12	Eyebolt Nut	Carbon Steel	A194-2H	A194-8
13	Locking Nut	Carbon Steel	Alloy Steel	Stainless Steel
14	Gland	A276-420	A276-304	A276-316
15	Gland Flange	A216-WCB	A217-WC6	A351-CF8M
16	Washer		Carbon Steel	
17	Stem Nut		Aluminum-Bronze ²⁾	
18	Bolt		Carbon Steel	
19	Handwheel		Malleable Iron	
20	Handwheel Washer		Carbon Steel	
21	Handwheel Nut		A194-2H	

Note: 1). Graphite optional
 2). Ductile Ni-Resist optional
 3). Wedge and seat ring may either be solid facing material or a base material equal to or better than the body/bonnet material with facing as shown.

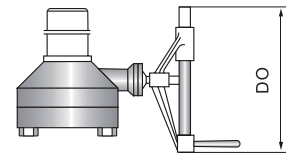
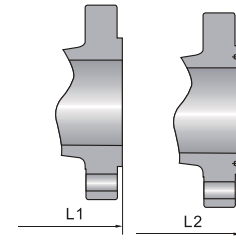
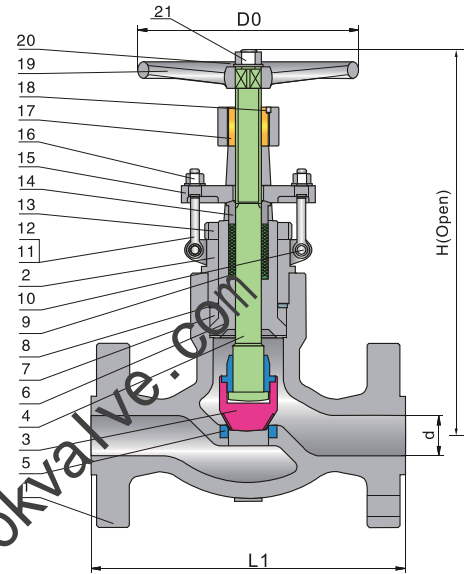

Dimensions data

NPS DN	2 50	2 $\frac{1}{2}$ 65	3 80	4 100	6 150	8 200	2 50	2 $\frac{1}{2}$ 65	3 80	4 100	6 150	in mm
	ANSI Class 1500Lb						ANSI Class 2500Lb					
L1 (BW)	8.50 216	10.00 254	12.00 305	16.00 406	22.00 559	28.00 711	11.00 279	13.00 330	14.50 368	18.00 457	24.00 610	in mm
L (RF)	14.50 368	16.50 419	18.50 470	21.50 546	27.75 705	32.75 832	17.75 451	20.00 508	22.75 578	26.50 673	36.00 914	in mm
L2 (RTJ)	14.62 371	16.62 422	18.62 473	21.62 549	28.00 711	33.12 842	17.88 454	20.50 514	23.00 584	26.88 683	36.50 927	in mm
H (OPEN)	22 557	22 557	24.38 620	30 760	44.62 1135	54.75 1390	23.38 595	23.38 595	28 710	32.25 820	49.62 1260	in mm
D0	16 400	18 450	20 500	24 600	28 700	36 900	16 400	20 500	24 600	28 700	36 900	in mm
WT (kg)	57 86	65 112	90 162	190 240	450 580	730 950	65 115	78 136	125 205	155 275	480 860	BW RF/RTJ