

PNEUMATIC ACTUATORS

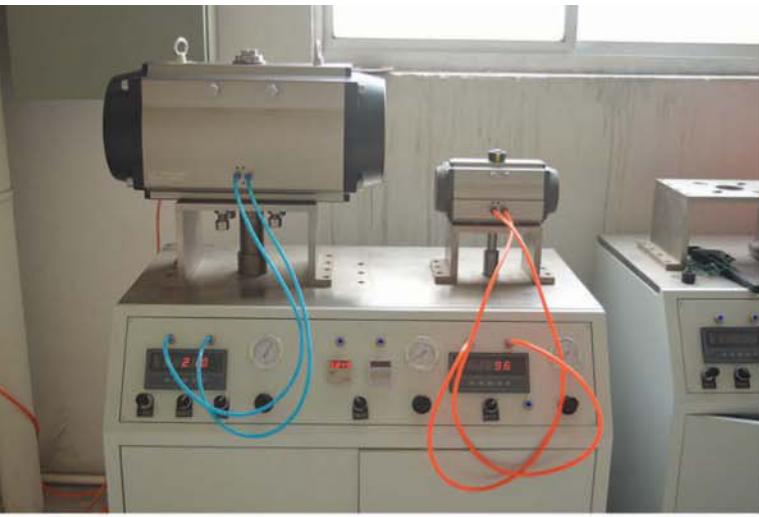

Flowspec Luokai Industrial Co., Ltd.





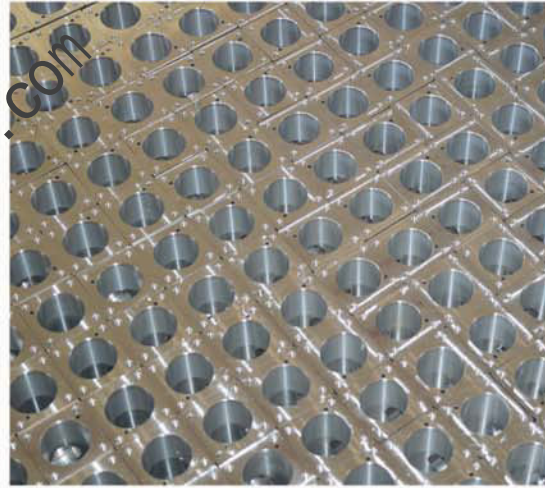

产品介绍 Product description

① 指示器 Indicator

NAMUR标准指示器便于安装位置开关、定位器等附件。

Position indicator with NAMUR is convenient for mounting accessories such as Limit Switch box, Positioner

② 输出轴 Pinion

镀镍合金钢、高精度一体式输出轴同时符合NAMUR、ISO5211、DIN3337标准。可根据客户要求定制尺寸和不锈钢材料。

The pinion is high-precision and integrative, made from nickelled-alloy steel, full conform to the latest standards of ISO5211, DIN3337, NAMUR. The dimensions can be customized and the stainless steel is available.

③ 缸体 Actuator Body

ASTM6005压铸铝合金缸体可以采用硬质氧化、环氧树脂喷涂（根据要求喷涂兰色、橙色、黄色等）、PTFE涂层或镀镍满足不同要求。

According to the different requirements, the extruded aluminum alloy ASTM6005 Body can be treated with hard anodized, powder polyester painted (different colours is available such as blue, orange, yellow etc.), PTFE or Nickel plated.

④ 端盖 End caps

压铸铝合金表面金属粉末喷涂各种颜色、PTFE涂层或镀镍处理。

Die-casting aluminum powder polyester painted in different colours, PTFE or Nickel plated

⑤ 活塞 Pistons

双活塞齿条、采用铸铝硬质氧化或者铸钢镀锌处理，安装位置对称、运作迅速、使用寿命长，简单的颠倒活塞可以改变旋转方向。

The twin rack pistons are made from Die-casting aluminum treated with hard anodized or made from cast steel with galvanization. Symmetric mounting position, long cycle life and fast operation, reversing rotation by simply inverting the

⑥ 行程调节 Travel adjustment

两个独立的行程调节螺钉可以进行方便精确 $\pm 5^\circ$ 的调节开关位置。

The two independent external travel stop adjustment bolts can adjust $\pm 5^\circ$ at both open and close directions easily and precisely.



⑦ 高性能弹簧 High performance springs

采用优质材料、涂层处理、预压装配。具有较强的抗腐蚀性和使用寿命。能够按期、简单的拆卸单作用执行器，通过改变弹簧数量满足不同的力矩输出范围。

Preloaded coatings springs are made from the high quality material for resistant to corrosion and longer service life, which can be demounted safely and conveniently to satisfy requirement of torque by changing quantity of springs.

⑧ 轴承、导板 Bearing & Guides

采用低摩擦、长寿命复合材料，避免了金属与金属的直接接触，维修更换简单方便。

Made from low friction, long-life compound material, to avoid the direct contact between metals. The maintenance and replacement are easy and convenient.

⑨ 密封 O-rings

在常温工作条件使用丁腈橡胶，在高温或低温时采用氟橡胶或硅橡胶。

NBR rubber O-rings provide trouble-free operation at standard temperature ranges. For high and low temperature applications Viton or Silicone.



零件和材料 Parts and Material

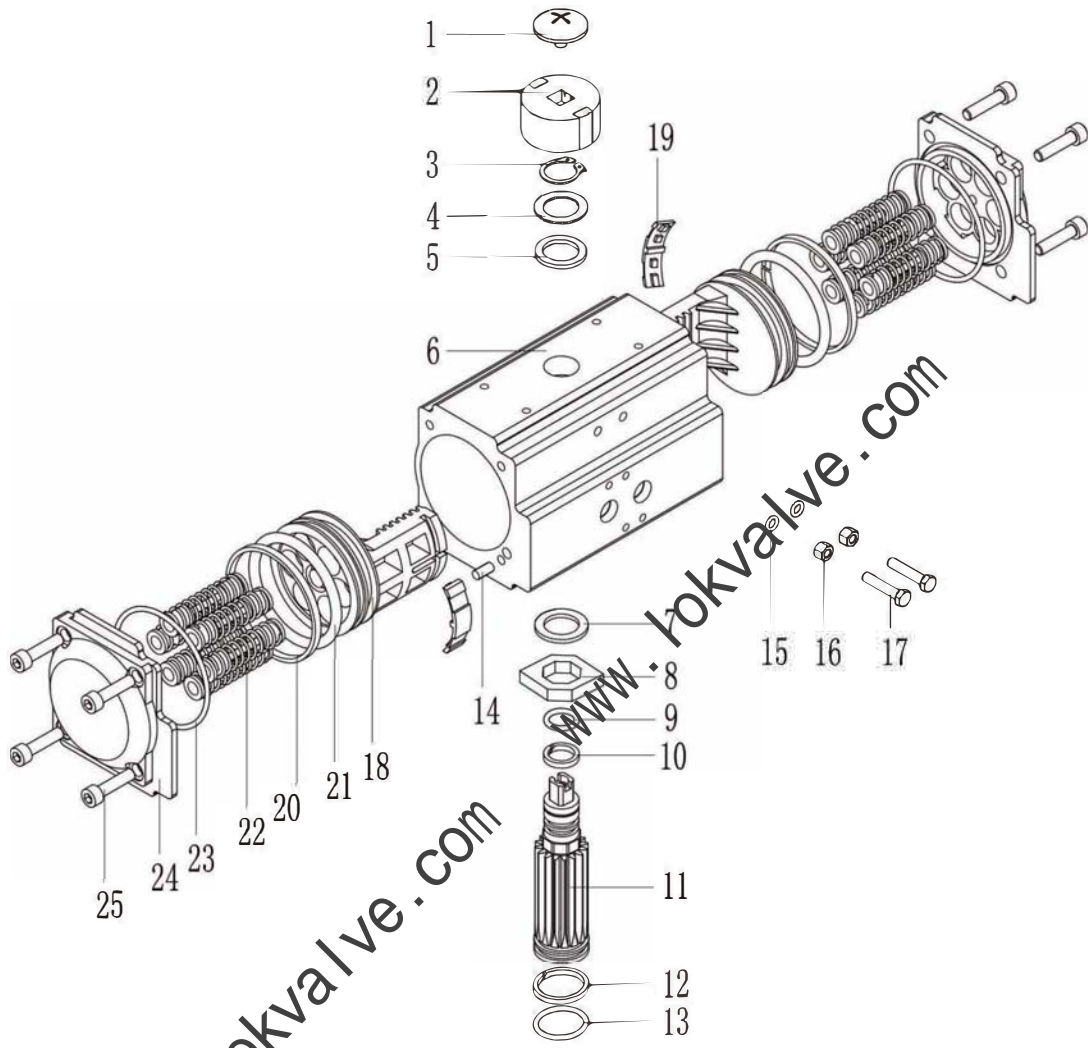



参数 Parameters

序号	名称	数量	材料	防腐处理	可选材料
1	指示器螺钉	1	塑料		
2	指示器	1	塑料		
3	轴挡	1	不锈钢		
4	金属垫片	1	不锈钢		
5	外垫片	1	工程塑料		
7	内垫片	1	工程塑料		
10	上轴支撑圈	1	工程塑料		
12	下轴支撑圈	1	工程塑料		
20	活塞支撑圈	1	工程塑料		
9	上轴O型圈	1	丁腈橡胶		氟橡胶/硅橡胶
13	下轴O型圈	1	丁腈橡胶		氟橡胶/硅橡胶
15	调节螺栓O型圈	2	丁腈橡胶		氟橡胶/硅橡胶
21	活塞O型圈	2	丁腈橡胶		氟橡胶/硅橡胶
23	端盖O型圈	2	丁腈橡胶		氟橡胶/硅橡胶
14	塞头	2	丁腈橡胶		氟橡胶/硅橡胶
16	螺母	2	不锈钢		
17	调节螺栓	2	不锈钢		
18	活塞	2	压铸铝合金	硬质氧化	
19	活塞导板	2	工程塑料		
6	缸体	1	铝合金	硬质氧化	
8	凸轮	1	合金钢		
11	轴	1	合金钢	镀镍	不锈钢
22	弹簧	0~12	弹簧钢	浸漆	
24	端盖	2	压铸铝合金	粉末喷涂	
25	端盖紧固螺栓		不锈钢		

NO.	Description	Qty	Standard Material	Protection	Optional Material
1	Indicator screw	1	Plastic		
2	Indicator	1	Plastic		
3	Axis block	1	Stainless steel		
4	Metal gasket	1	Stainless steel		
5	Outside washer	1	Engineering plastics		
7	Inside washer	1	Engineering plastics		
10	Shaft support ring	1	Engineering plastics		
12	Lower shaft support ring	1	Engineering plastics		
20	Piston support ring	1	Engineering plastics		
9	Bearing(Pinion top)	1	NBR		Viton/Silicone
13	Bearing(Pinion bottom)	1	NBR		Viton/Silicone
15	O-ring(Adjusting bolt)	2	NBR		Viton/Silicone
21	O-ring(Piston)	2	NBR		Viton/Silicone
23	Plug	2	NBR		Viton/Silicone
14	Plugs	2	NBR		Viton/Silicone
16	Screw nut	2	Stainless steel		
17	Adjusting bolt	2	Stainless steel		
18	Piston	2	Die-casting aluminum	Hard anodized etc	
19	Piston guides	2	Stainless steel		
6	Body	1	Aluminum	Hard anodized etc	
8	Cam	1	Alloy steel		
11	Axis	1	Alloy steel	Nickel plated	Stainless steel
22	Spring	0~12	Spring steel	Dip coating	
24	End cap	2	Die-casting aluminum	Powder polyster painted etc	
25	End cap fastening bolt	8	Stainless steel		

工作原理 Operating Principle

双作用执行器 Double Acting Actuators

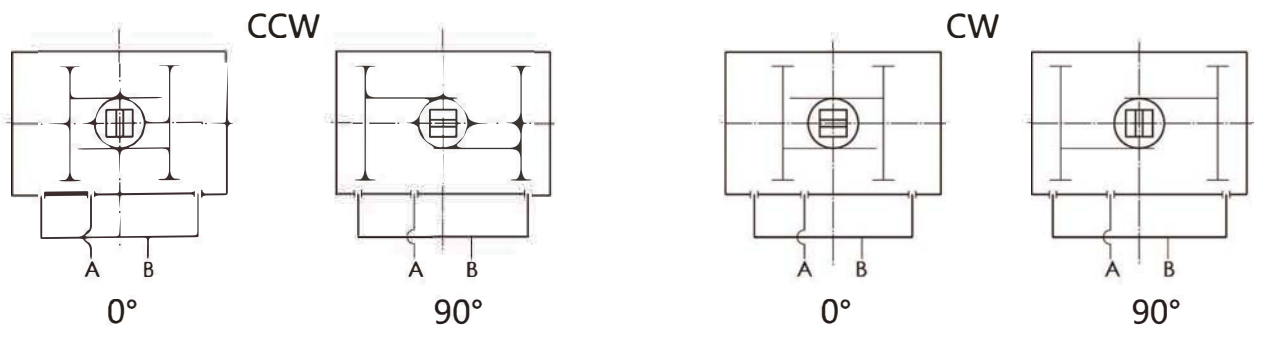

A口进气，压缩空气推动活塞向外运动，使执行器输出轴逆时针旋转（0°→90°），B口排气。
 B口进气，压缩空气推动活塞向内运动，使执行器输出轴顺时针旋转（90°→0°），A口排气。

Air to Port A forces the pistons outwards, causing the pinion to turn counterclockwise while the air is being exhausted from Port B.
 Air to Port B forces the pistons inwards, causing the pinion to turn clockwise while the air is being exhausted from Port A.

A口进气，压缩空气推动活塞向外运动，使执行器输出轴顺时针旋转（0°→90°），B口排气。
 B口进气，压缩空气推动活塞向内运动，使执行器输出轴逆时针旋转（90°→0°），A口排气。

Air to Port A forces the pistons outwards, causing the pinion to turn clockwise while the air is being exhausted from Port B.
 Air to Port B forces the pistons inwards, causing the pinion to turn counterclockwise while the air is being exhausted from Port A.

单作用执行器 Spring Return Actuators

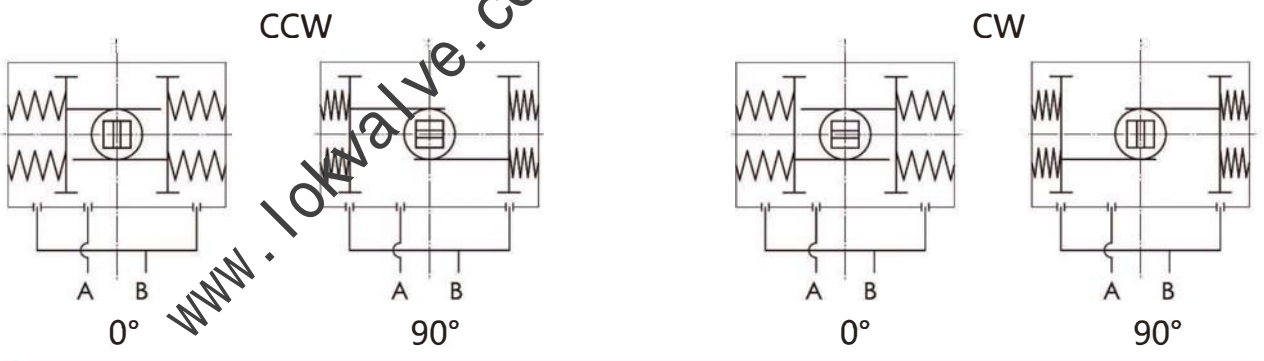

A口进气，压缩空气克服弹簧力，推动活塞向外运动，执行器输出轴逆时针转动（0°→90°），B口排气；
 执行器失气，活塞在弹簧力的作用下向内运动，执行器输出轴顺时针转动（90°→0°），A口排气。

Air to Port A forces the pistons outwards, causing the springs to compress. The pinion turns counterclockwise while air is being exhausted from port B.
 Loss of air pressure on port A, the stored energy in the springs forces the pistons inwards. The pinion turns clockwise while air is being exhausted from port A.

A口进气，压缩空气克服弹簧力，推动活塞向外运动，执行器输出轴顺时针转动（0°→90°），B口排气；
 执行器失气，活塞在弹簧力的作用下向内运动，执行器输出轴逆时针转动（90°→0°），A口排气。

Air to Port B forces the pistons outwards, causing the springs to compress. The pinion turns counterclockwise while air is being exhausted from port B.
 Loss of air pressure on port A, the stored energy in the springs forces the pistons inwards. The pinion turns clockwise while air is being exhausted from port A.

双作用输出力矩 Output Torque Of Double Acting Actuators

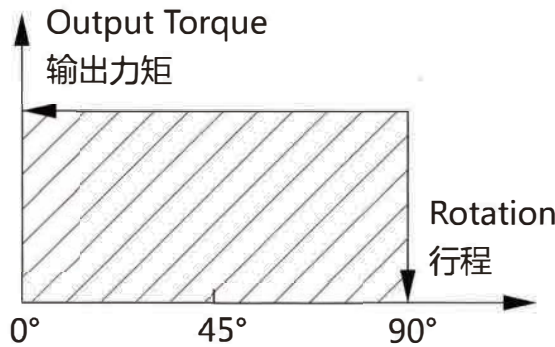

Unit:Nm

型号Model	气源压力Air supply pressure(Unit:bar)									
	2	2.5	3	4	4.5	5	5.5	6	7	8
DA-32	3	4	5	6	7	8	8	9	11	12
DA-40	5	6	7	10	11	12	13	14	17	19
DA-52	8	10	12	16	18	20	22	24	28	32
DA-63	15	18	22	29	33	36	40	44	51	58
DA-75	20	25	30	40	45	50	55	60	70	80
DA-83	31	39	47	63	70	78	86	94	110	125
DA-92	45	56	68	90	102	115	124	135	158	181
DA-105	66	83	99	132	149	165	182	198	231	264
DA-125	100	125	150	200	226	251	276	301	351	401
DA-140	171	214	256	342	385	427	470	513	598	684
DA-160	266	332	399	532	598	665	731	798	931	1064
DA-190	426	532	638	851	958	1064	1170	1277	1490	1702
DA-210	532	665	798	1064	1197	1330	1463	1596	1862	2128
DA-240	769	962	1154	1539	1731	1924	2116	2308	2693	3078
DA-270	1170	1462	1754	2339	2632	2924	3216	3509	4094	4679
DA-300	1526	1908	2289	3052	3434	3815	4197	4578	5341	6104
DA-350	2285	2856	3427	4570	5141	5712	6283	6854	7997	9139
DA-400	3256	4070	4884	6512	7326	8140	8954	9768	11396	13024

双作用执行器的选型：

在正常操作条件下，双作用执行器考虑的安全系数为20%-30%。

示例：

- 阀门力矩=100Nm
- 安全力矩=100×(1+30%)=130Nm
- 气源压力=5Bar

对照双作用力矩表，选配双作用执行器最小规格为DA105。

Sizing:Double Acting Actuator

The suggested safety factor for double acting actuators under normal working conditions is 20%-30%.

Example:

- The torque needed by valve=100N·m
- The torque considered safety factor(1+30%)=130N·m
- Air Supply=5Bar

According to the above table,we can choose the minimum model is DA105.

单作用输出力矩 Output Torque Of Spring Return Actuators

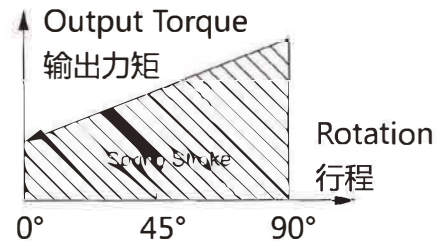
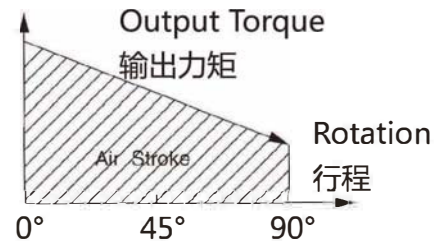

Unit:Nm

		输出扭矩Output torque of air to springs														Springs' output	
气压Air pressure	Spring Qty.	2.5BAR		3BAR		4BAR		5BAR		6BAR		7BAR		8BAR		90°	0°
型号Model		0° Start	90° End	0° Start	90° End	0° Start	90° End	0° Start	90° End	0° Start	90° End	0° Start	90° End	0° Start	90° End	Start	End
SR-52	K5	5.7	3.8	7.6	5.7											6.2	4.3
	K6	4.9	2.5	6.9	4.5	10.9	8.5									7.4	5.0
	K7	4.0	1.3	6.0	3.3	9.8	7.3	14.0	10.4							8.6	5.9
	K8			5.2	2.0	9.2	6.0	13.2	9.1	17.2	14.1					9.9	6.7
	K9			4.3	0.8	8.3	4.8	12.3	7.9	16.3	12.8	20.3	16.8			11.1	7.6
	K10					7.4	3.6	11.5	6.7	15.5	11.6	19.5	15.8			12.4	8.5
	K11					6.6	2.3	10.6	5.4	14.6	10.4	18.6	14.3	22.6	18.3	13.6	9.3
	K12								9.7	4.2	13.8	9.1	17.8	12.2	21.8	17.1	14.8
SR-63	K5	11.4	7.7	15.0	11.4	22.3	14.9									10.4	6.8
	K6	10.1	5.7	13.6	9.3	20.9	16.6	28.3	23.9							12.5	8.2
	K7	8.6	3.6	12.5	7.2	19.5	14.5	26.8	21.9							14.6	9.6
	K8			10.9	5.1	18.2	12.4	25.5	19.8	32.8	27.0	40.1	34.3			16.7	10.9
	K9					16.8	10.4	24.1	17.7	31.4	24.9	38.7	32.2			18.8	12.3
	K10					1.4	8.2	22.8	15.6	30.0	22.8	37.3	30.1	44.7	37.4	20.9	13.7
	K11							21.5	13.5	28.7	20.7	36.0	28.0	43.3	35.3	22.9	15.0
	K12								20.0	11.4	27.3	18.6	34.6	25.9	41.9	33.3	25.0
SR-75	K5	14.5	10.6	19.4	15.5	29.5	25.7									14.5	10.5
	K6	12.4	7.6	17.3	12.6	27.4	22.7	37.5	32.8							17.4	12.7
	K7	10.4	4.8	15.2	9.7	25.3	19.9	35.4	29.9							20.3	14.8
	K8			13.1	6.8	23.1	16.9	33.3	27.0	43.2	37.0	53.3	47.0			23.2	16.9
	K9					21.0	14.1	31.2	24.1	41.1	34.1	51.2	44.2			26.1	19.0
	K10					19.0	11.1	29.1	21.2	39.0	31.2	49.1	41.2	59.1	51.2	29.0	21.1
	K11							24.9	18.3	37.0	28.3	47.0	38.4	57.0	48.4	31.9	23.2
	K12								24.9	15.4	34.9	25.4	44.9	35.4	54.9	45.4	34.7
SR-83	K5	23.3	16.1	31.1	24.0	46.8	39.7									23.0	15.8
	K6	20.1	11.5	28.0	19.3	43.7	35.1	59.4	50.7							27.6	19.0
	K7	17.0	6.9	24.8	14.8	40.5	30.5	56.2	46.2							32.2	22.1
	K8			21.7	10.1	37.4	25.8	53.1	41.5	68.8	57.2	84.5	72.9			36.8	25.3
	K9					34.2	21.3	49.9	37.0	65.6	52.6	81.2	68.3			41.4	28.5
	K10					32.1	16.6	46.7	32.3	62.4	48.0	78.1	63.7	93.8	79.3	46.0	31.6
	K11							43.6	27.7	59.3	43.4	75.0	59.1	90.6	74.8	50.6	34.8
	K12							40.4	23.2	56.1	38.9	71.7	54.5	87.4	70.2	55.2	38.0
SR-92	K5	33.1	22.0	44.2	32.0	66.8	55.9									34.4	23.3
	K6	28.4	15.2	39.6	26.2	62.2	49.0	84.8	71.6							41.2	28.0
	K7	23.8	8.2	34.9	19.4	57.5	42.1	80.2	64.7							48.1	32.7
	K8			31.3	12.6	52.9	35.2	75.5	57.9	98.1	80.5	120.7	103.0			55.0	37.3
	K9					48.2	28.4	70.9	51.0	93.5	73.6	116.0	96.1			61.9	42.0
	K10					43.6	21.5	66.2	44.1	88.8	66.7	111.3	89.2	134.0	111.8	68.7	46.7
	K11							61.5	37.2	84.1	59.9	106.6	82.4	129.2	105.0	75.6	51.4
	K12								56.8	30.4	79.4	53.0	101.9	75.5	124.5	98.1	82.5
SR-105	K5	51.0	33.4	67.5	49.9	100.6	83.0									49.2	31.6
	K6	44.7	23.5	61.1	40.0	94.2	73.2	127.3	106.2							59.1	38.0
	K7	38.4	13.7	54.9	30.3	87.9	63.4	121.0	96.4							68.9	44.3
	K8			48.5	20.4	81.6	53.5	114.7	86.5	147.7	119.6	180.8	152.7			78.7	50.6
	K9					75.3	43.7	108.4	76.8	141.5	109.8	174.5	142.9			88.6	56.9
	K10					68.9	33.4	102.0	66.5	135.1	99.6	168.2	132.6	201.2	165.7	98.4	63.3
	K11							95.7	57.0	128.7	90.1	161.8	123.1	194.8	156.2	108.3	69.6
	K12							89.4	47.5	122.5	80.6	155.5	113.6	188.6	146.7	118.1	75.9
SR-125	K5	73	47	98	72	148	122									79	52
	K6	63	31	88	56	138	107	188	157							94	63
	K7	52	15	77	40	127	90	178	141							110	73
	K8			67	25	117	75	167	125	217	176	268	226			125	84
	K9					107	59	157	109	207	159	257	210			141	94
	K10					96	44	146	94	196	144	247	194	297	245	157	105
	K11							136	78	186	128	236	178	286	228	173	115
	K12							125	63	176	113	226	163	276	213	188	125
SR-140	K5	128	85	171	127	256	213									129	86
	K6	111	59	154	102	239	187	325	273							155	103
	K7	94	33	137	76	222	162	308	247							181	120
	K8			120	50	205	136	291	221	376	307	462	392			206	137
	K9					187	110	273	196	358	281	444	367			232	155
	K10					170	84	256	169	341	255	427	340	512	426	258	172
	K11							238	143	324	229	409	314	495	400	284	189
	K12							221	118	307	203	392	289	478	374	310	206



Unit:Nm

气压Air pressure		输出扭矩Output torque of air to springs														Springs' output	
型号Model	Spring Qty.	2.5BAR		3BAR		4BAR		5BAR		6BAR		7BAR		8BAR		90°	0°
		0° Start	90° End	0° Start	90° End	0° Start	90° End	0° Start	90° End	0° Start	90° End	0° Start	90° End	0° Start	90° End		
SR-160	K5	193	124	259	191	392	324									208	140
	K6	165	83	232	149	365	282	498	415							250	168
	K7	137	41	203	107	336	240	469	373							292	196
	K8			176	66	309	199	442	237	575	465	708	598			333	223
	K9					280	157	413	290	546	423	679	556			375	251
	K10					253	115	386	248	519	381	652	514	785	647	417	279
	K11							358	207	491	340	624	473	757	606	458	307
K12							330	165	463	298	596	431	729	564	500	335	
SR-190	K5	332	222	438	329	651	542									309	200
	K6	292	161	398	267	611	480	824	693							371	240
	K7	252	99	358	205	571	418	784	631							433	280
	K8			318	143	531	356	744	569	957	782	1169	995			495	320
	K9					491	295	704	507	917	720	1130	933			557	360
	K10					451	233	664	446	877	658	1090	871	1302	1084	618	400
	K11							624	384	837	597	1050	848	1263	1022	680	440
K12							584	322	797	535	1010	748	1223	960	742	480	
SR-210	K5	390	285	523	418	789	684									380	275
	K6	335	209	468	342	734	608	1000	874							456	330
	K7	280	133	413	266	679	532	945	798							532	385
	K8			358	190	624	456	890	722	1156	988	1422	1254			608	440
	K9					569	380	835	646	1101	912	1367	1178			684	495
	K10					514	304	780	570	1046	836	1312	1102	1578	1368	760	550
	K11							725	494	991	760	1257	1026	1523	1292	836	605
K12							670	418	988	684	1202	950	1468	1216	912	660	
SR-240	K5	552	409	744	600	1129	985									554	410
	K6	470	297	662	489	1047	874	1432	1259							665	492
	K7	388	187	580	379	964	764	1349	1149							775	575
	K8			498	268	883	653	1267	1037	1652	1422	2037	1807			886	656
	K9					800	542	1185	926	1569	1311	1954	1696			998	739
	K10					718	431	1103	816	1488	1201	1872	1586	2257	1970	1108	821
	K11							1031	705	1406	1090	1791	1474	2176	1859	1219	903
K12							939	594	1323	979	1708	1363	2093	1748	1330	985	
SR-270	K5	903	675	1195	968	1779	1556									787	560
	K6	790	519	1083	811	1667	1336	2252	1981							943	672
	K7	679	361	972	654	1556	1238	2141	1823							1101	783
	K8			860	497	1444	1081	2029	1666	2614	2252	3199	2836			1258	895
	K9					1331	923	1917	1509	2502	2094	3087	2678			1416	1007
	K10					1220	767	1805	1352	2390	1937	2974	2521	3560	3107	1572	1119
	K11							1693	1194	2278	1779	2862	2364	3448	2949	1730	1231
K12							1582	1037	2167	1623	2751	2207	3336	2792	1887	1342	
SR-300	K5	1097	729													1061	730
	K6	935	494	1316	875											1273	876
	K7	772	258	1101	639	1916	1402									1485	1022
	K8			998	403	1754	1166	2517	1929							1697	1168
	K9					1592	930	2355	1693	3118	2456					1909	1314
	K10					1430	695	2193	1458	2956	2221	3719	2984	4482	3747	2122	1460
	K11							2030	1222	2793	1985	3556	2748	4319	3511	2334	1606
K12							1868	986	2631	1749	3394	2512	4157	3275	2546	1752	
SR-350	K5	1553	964													1702	1173
	K6	1292	586	1863	1157											2043	1408
	K7	1031	208	1602	779	2745	1922									2383	1642
	K8			1341	401	2484	1544	3626	2686							2724	1877
	K9					2224	1165	3336	2307	4508	3449					3064	2112
	K10					1963	787	3105	1929	4247	3071	5390	4214	6532	5356	3405	2346
	K11							2844	1551	3986	2693	5129	3836	6271	4978	3745	2581
K12							2584	1172	3726	2314	4869	3457	6011	4599	4086	2816	
SR-400	K7	2028	869													2880	1837
	K8	1736	411	2550	1225											3292	2100
	K9			2259	768	3887	2396									3703	2362
	K10			1967	311	3595	1939	5223	3567							4115	2624
	K11					3303	1482	4931	3110	6559	4738					4526	2887
	K12					3012	1025	4640	2653	6268	4281	7895	5908	9523	7536	4938	3149
	K13							4348	2195	5976	3823	7603	5450	9231	7078	5349	3412
	K14							4057	1738	5685	3366	7312	4993	8940	6621	5761	3674
K15							3765	1281	5393	2909	7020	4536	8648	6164	6172	3937	
K16									5101	2452	6728	4079	8356	5707	6584	4199	

外形尺寸 Dimension

DA/SR-32

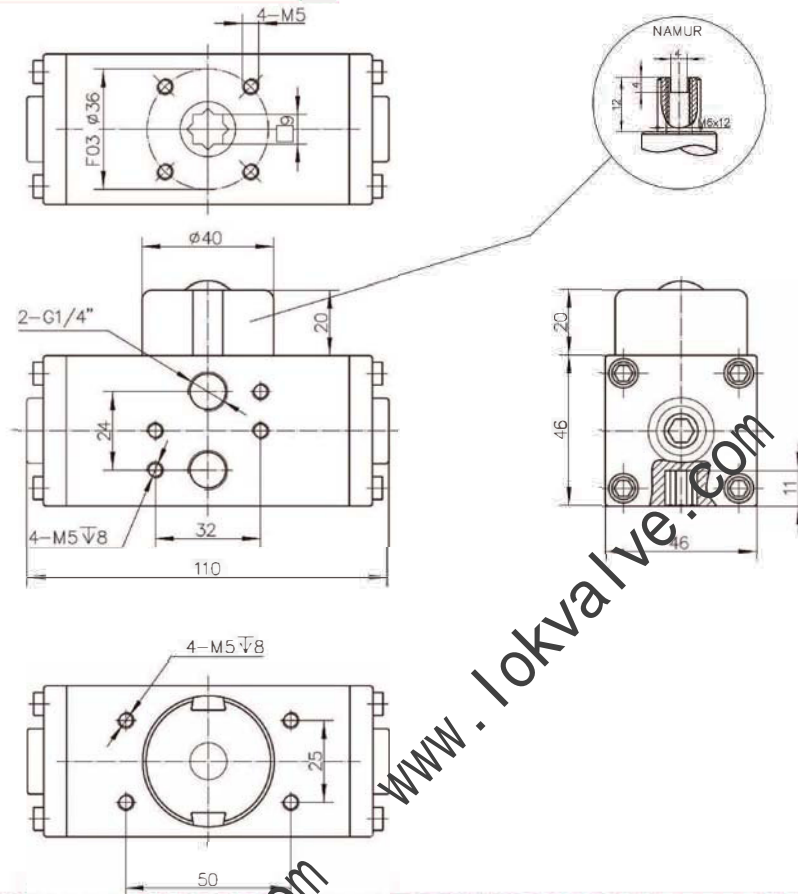

DA/SR-40

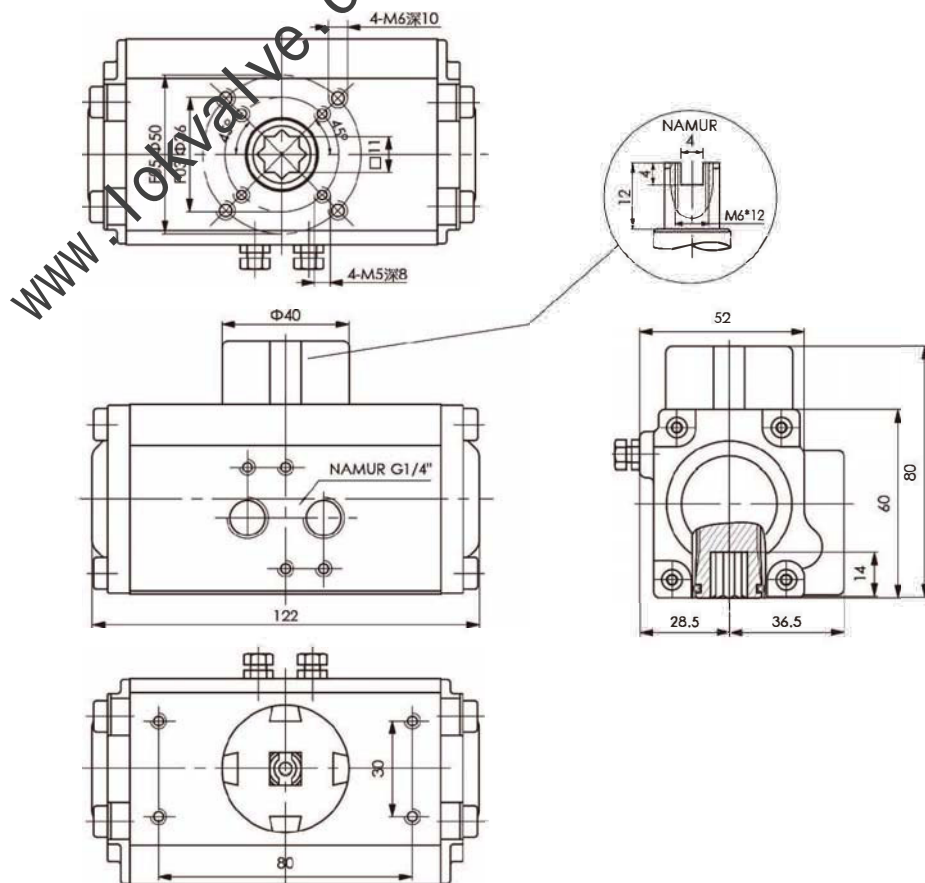

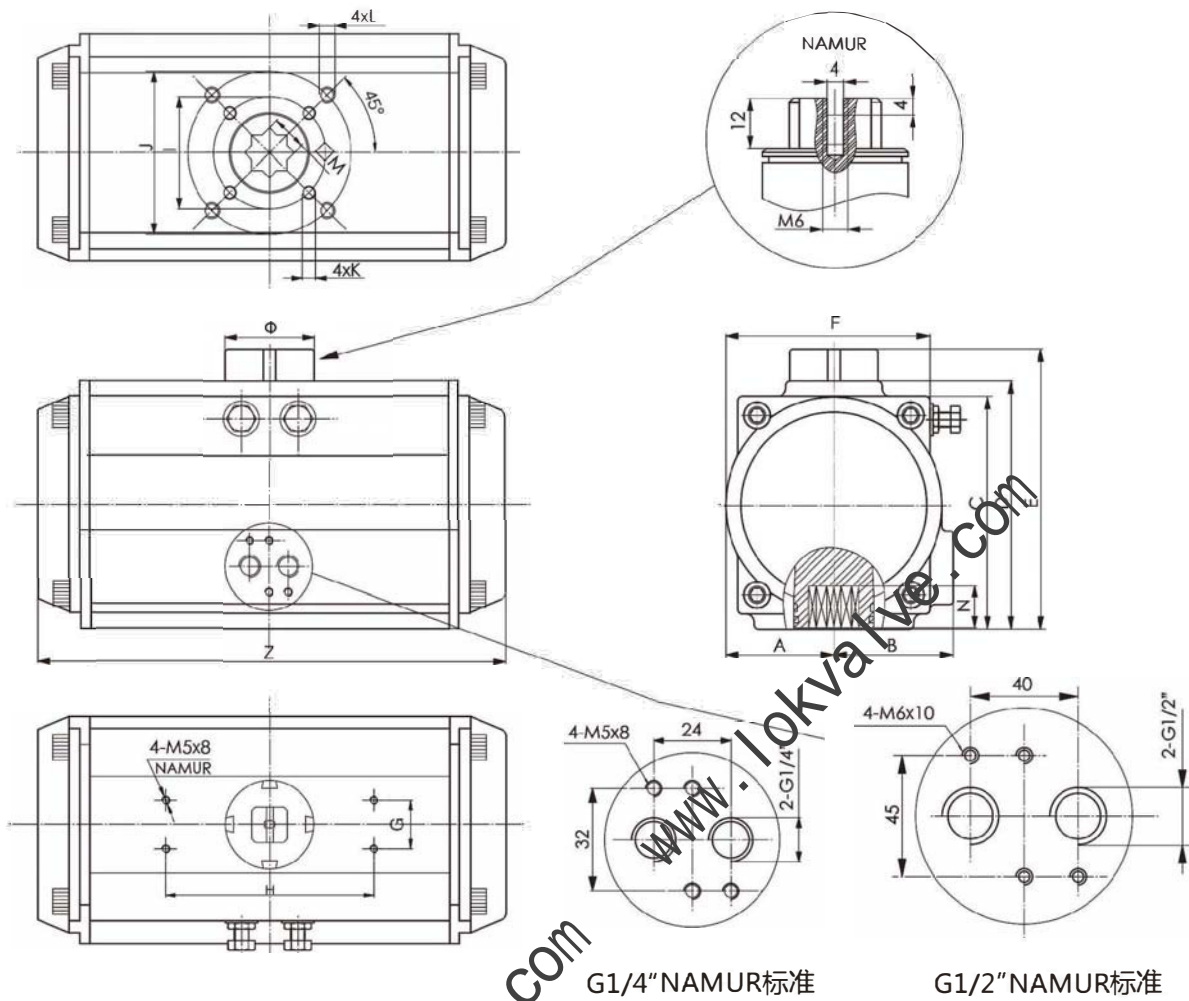

执行器安装尺寸表

型号Model									连接孔								气源接口 Air Connection
	A	B	C	D	E	G	H	I	J	K	L	M	N	Z	Φ		
DA/SR-32	23	23	46	46	60	46	25	50		Φ36		M5x8	9	11	110	Φ40	NAMUR G1/4"
DA/SR-40	28.5	36.5	60	60	80	52	30	80	Φ36	Φ50	M5x8	M6x10	11	14	122	Φ40	NAMUR G1/4"
DA/SR-52	30	41.5	65.5	72	92	65	30	80	Φ36	Φ50	M5x8	M6x10	11	14	147	Φ40	NAMUR G1/4"
DA/SR-63	36	47	81	81	108	72	30	80	Φ50	Φ70	M6x10	M8x13	14	18	168	Φ40	NAMUR G1/4"
DA/SR-75	42	53	94	99.5	119.5	81	30	80	Φ50	Φ70	M6x10	M8x13	14	18	184	Φ40	NAMUR G1/4"
DA/SR-83	46	57	98.5	108.7	128.7	92	30	80	Φ50	Φ70	M6x10	M8x13	17	21	204	Φ40	NAMUR G1/4"
DA/SR-92	50	58.5	111	116.5	136.5	98	30	80	Φ50	Φ70	M6x10	M8x13	17	21	262	Φ40	NAMUR G1/4"
DA/SR-105	57.5	64	122.5	133	153	109.5	30	80	Φ70	Φ102	M8x13	M10x16	22	26	268	Φ40	NAMUR G1/4"
DA/SR-125	67.5	74.5	145.5	155	185	127.5	30	130	Φ70	Φ102	M8x13	M10x16	22	26	301	Φ55	NAMUR G1/4"
DA/SR-140	75	77	161	172	202	137.5	30	130	Φ102	Φ125	M10x16	M12x20	27	31	390	Φ55	NAMUR G1/4"
DA/SR-160	87	87	184	197	227	159	30	130	Φ102	Φ125	M10x16	M12x20	27	31	458	Φ55	NAMUR G1/4"
DA/SR-190	103	103	215	230	260	189	30	130		Φ140		M16x25	36	40	525	Φ80	NAMUR G1/4"
DA/SR-210	113	113	235.5	255	285	210	30	130		Φ140		M16x25	36	40	532	Φ80	NAMUR G1/4"
DA/SR-240	130	130	264.5	289	319	245	30	130		Φ165		M20*25	46	50	602	Φ80	NAMUR G1/4"
DA/SR-270	147	147	299	326	356	273	30	130		Φ165		M20*25	46	50	718	Φ80	NAMUR G1/2"
DA/SR-300	162	174	330	350	380	312	30	130		Φ165		M20*25	46	50	760	Φ80	NAMUR G1/2"
DA/SR-350	190	195	483	410	440	365	30	130	Φ165	Φ254	M20*25	8xM16*25	46	50	920	Φ80	NAMUR G1/2"
DA/SR-400	260	260	466	466	496	298	30	130	Φ165	Φ254	M20*25	8xM16*25	46	50	940	Φ80	NAMUR G1/2"

单作用执行器的选择 Sizing: Spring Return Actuators

在正常工作条件下，单作用执行器考虑的安全系数为30%-50%

例如：

阀门需要力矩=80N·m

安全力矩=80 (1+30%) =104N·m

气源压力=5Bar

对照单作用执行器输出力矩表，我们可以查到SR140

K7输出力矩为

空气行程0°=308N·m

空气行程90°=247N·m

弹簧行程90°=181N·m

弹簧行程0°=120N·m

所有输出力矩均大于我们需求。

注意：

单作用执行器弹簧复位过程中，执行器B口通气不影响执行器输出力矩，相反帮助弹簧的复位。

The suggested safety factor for spring return actuator under normal working conditions is 30-50%

Example:

The torque needed by valve=80N.m

The torque consider safety

factor(1+30%)=104N·m

Air Supply=5Bar

According to the table of spring return actuators' output,

we find out torque of SR140 K7 is:

Air stroke 0°=308N·m

Air stroke 90°=247N·m

Spring stroke 90°=181N·m

Spring stroke 0°=120N·m

All the output torque is large than we needed.

Attention

During the restoration,the spring return

actuators' output will not be affected by the

inputing air from the port B.On the contrary , it

will help the restoration of springs.

单作用执行器弹簧安装形式 Spring mounting form for spring return actuators

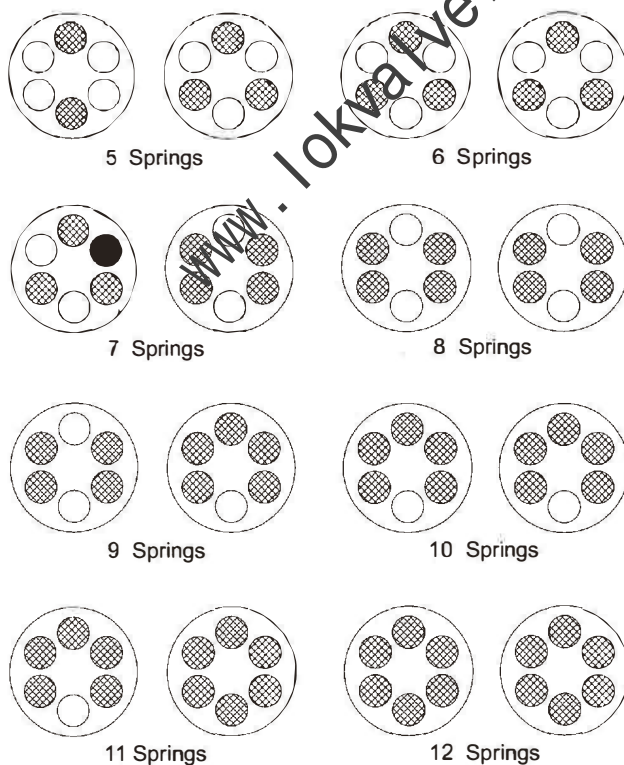

在单作用执行器的选配过程中，如果能够了解阀门在开启、运行和关闭时的扭矩分配，我们就可以更加经济、更加合理地选配执行器。

During selecting the spring return actuators,we can choose the more reasonable and more economical actuators,if we know the different torque needed by the valve working at opening, operating and closing.

Example:

The max torque needed by the butterfly valve=104N.m

The torque after opened(operating)104×30%=32N.m

Air Supply=5Bar

We can select the SR125K11 output torque is:

Air stroke 0°136N.m>104N.m

Air stroke 90°=78N.m>32N.m

Spring stroke 90°=173N.m > 32N.m

Spring stroke 0°=115N.m > 104N.m

The above datas show the actuator' s torque can satisfy

the requirement of the butterfly valve.

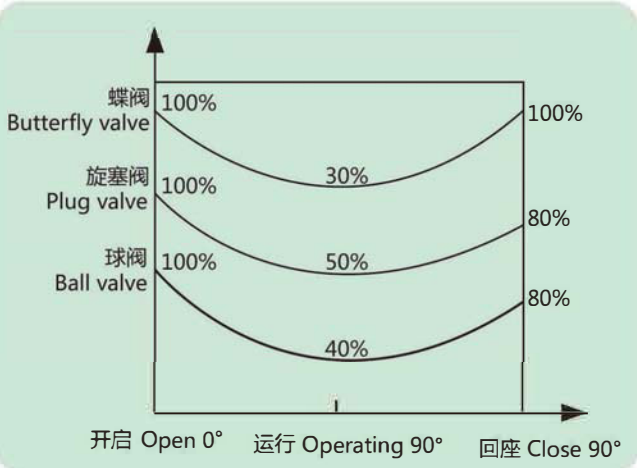

例如：
 蝶阀原最大扭矩=104N·m
 打开后扭矩104×30%=32N·m
 气源压力=5Bar
 我们可以选择 SR125 K11
 空气行程0°=136N·m>104N·m
 空气行程90°=78N·m>32N·m
 弹簧行程90°=173N·m>32N·m
 弹簧行程0°=115N·m>104N·m
 以上数据显示可以满足该蝶阀的正常启闭。

注意 确保执行器的输出扭矩和驱动阀门所需要的扭矩相符（执行器的型号和气源压力）。
 请注意，选型扭矩不仅取决于阀门，还要考虑相关的工况、安全系数等参数。

Note Make sure that the torque necessary to operate the valve is compatible with the actuator torque (it depends on both actuator type and air supply).
 Please note that the requested torque depends not only on the valve, but on the working conditions and the safety margins of the plant in question, too.

www.lokvalve.com

重量表 Weight Table

型号Model	32	40	52	63	75	83	92	105	125
重量 (DA)	0.7kg	1kg	1.4kg	2kg	2.7kg	3.1kg	4.6kg	6.8kg	8.9kg
重量 (SR)	-	1.1kg	1.5kg	2.1kg	2.9kg	3.6kg	5.2kg	6.9kg	10.1kg

型号Model	140	160	190	210	240	270	300	350	400
重量 (DA)	13kg	20kg	31kg	47kg	67kg	97kg	110kg	186kg	289kg
重量 (SR)	15kg	24kg	35kg	55kg	80kg	118kg	130kg	234kg	360kg

注：1、SR为12根弹簧；2、重量为净重量

耗气量 Air Consumption

开向体积和关向体积 Air Volume Opening & Closing

型号Model	Air volume opening 开向体积 (升)	Air volume closing 关向体积 (升)
32	0.04	0.05
40	0.08	0.11
52	0.12	0.16
63	0.21	0.23
75	0.3	0.34
83	0.43	0.47
92	0.64	0.73
105	0.95	0.88
125	1.6	1.4

型号Model	Air volume opening 开向体积 (升)	Air volume closing 关向体积 (升)
140	2.5	2.2
160	3.7	3.2
190	5.9	5.4
210	7.5	7.5
240	11	9
270	17	14
300	23.8	29.7
350	35.1	46.3
400	52.6	56

耗气量取决于供气压力、开关行程、体积及动作次数，计算如下：

$$\text{升/分} = \text{气缸体积 (开向体积 + 关向体积)} \times \left[\frac{\text{供气压力 (Kpa)} + 101.3}{101.3} \right] \times \text{次数/分钟}$$

Air consumption rest with Air Supply. Air volume and Action cycle times, expressions:

$$\text{L/Min} = \text{Air volume (Air volume Opening + Air volume closing)} \times \left[\frac{\text{Air Supply (Kpa)} + 101.3}{101.3} \right] \times \text{Action cycle times/min}$$

120° , 135° , 180° 双作用与单作用 Double Acting And Spring Return

为满足不同类型阀门及机械自动化的驱动要求，我司可根据客户的要求定制不同行程（例120°,135°,180°等）的气动执行器。

In order to meet the special requirements of control valve we produced special strokes actuators on consumer request(e.g.120°,135°,180°etc.)

输出扭矩 Output Torque

输出扭矩参考90°行程气动执行器扭矩表

Output Torque of double acting actuators please refer to the torque of 90°actuators.

180°双作用执行器尺寸表 Length of DAx180°

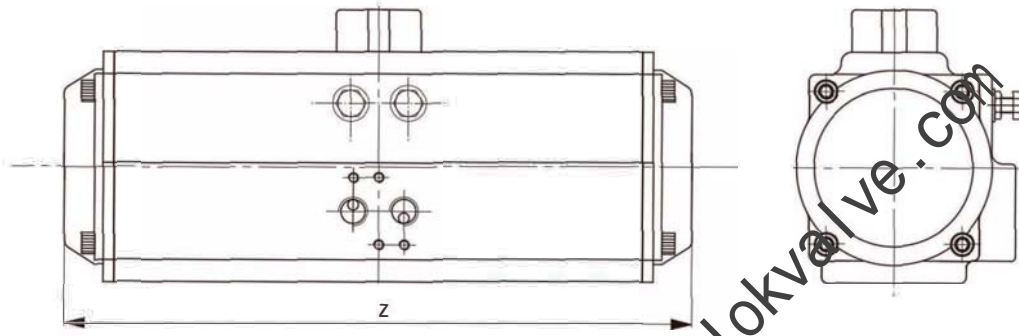

Size	52	63	75	83	92	105	125	140	160	190	210
Z(mm)	213	243	258	298	362	388	429	569	652	756	760

If you enquire any further information of spring return actuators,please do not hesitate to contact us.

三位式执行器 Three Position Pneumatic Actuator

三位式气动执行器是一种特殊规格的执行机构，提供了0°，45°，90°或0°，90°，180°的三位式操作方式。中间位置是依靠两个辅助活塞的移动产生的机械制动来实现的。中间位置是可调的。如90°行程的执行器能提供20°，30°，50°，70°等的中间位置。

Three position actuator provide an operation of 0°,45°,90°or 0°,90°,180°.The midway position is achieved by a mechanical stop of movement on the 2 auxiliary pistons. This midway stop positions adjustable. Example: 90°actuator can provide 20°,30°,40°,50°,70°etc.

输出扭矩 Output Torque

输出扭矩参考90°行程气动执行器扭矩表

Output Torque of double acting actuators please refer to the torque of 90°actuators.

90° 三位式双作用执行器尺寸表Length of DA-3P (90°)

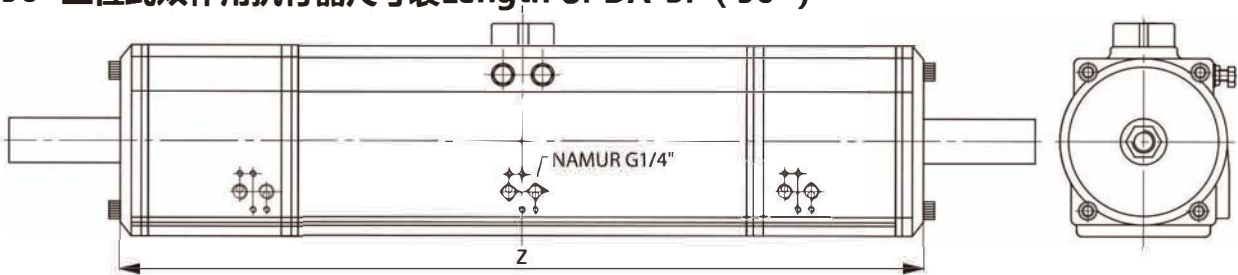

Size	52-3P	63-3P	75-3P	83-3P	92-3P	105-3P	125-3P	140-3P	160-3P	190-3P	210-3P
Z(mm)	266	303	336	298	394	410	456	570	646	788	788

If you enquire any further information of spring return actuators,please do not hesitate to contact us.

工作技术条件 Operating Conditions

- 1.工作介质
干燥或润滑的空气或无腐蚀性气体介质中杂质微粒小于30um.
- 2.气源压力
最小气源压力2.5巴，最大气源压力8巴。
- 3.介质环境温度
标准：-20℃ ~ +80℃
低温：-35℃ ~ +80℃
高温：-15℃ ~ +150℃
- 4.行程调节
0°和90°两个位置有±5°的调节范围
- 5.使用场合
室内或室外安装。

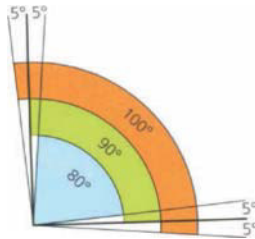

- 1.Operating media
Dry or lubricated air, or the non-corrosive gases
The maximum particle diameter must be less than 30 um
- 2.Air supply pressure
The minimum supply pressure is 2.5 Bar
The maximum supply pressure is 8 Bar
- 3.Operating temperature
standard:-20℃ ~ +80℃
Low temperature:-35℃ ~ +80℃
High temperature:-15℃ ~ +150℃
- 4.Travel adjustment
Have adjustment range of ±5° for the rotation at 0° and 90°
- 5.Application
Either indoor or outdoor

安装标准 Mounting Standard



气源接口复合NAMUR标准，可简单方便的安装电磁阀。

Air supply connection is designed in accordance with NAMUR standard to install solenoid valves.



输出轴的NAMUR标准槽和缸体上部标准安装孔，可使限位开关、定位器直接啮合和安装。

The NAMUR drive pinion and the NAMUR top mounting connection permit direct installation of accessories such as limit switch box and positioner.



底部安装孔设计符合ISO5211、DIN3337标准，可以直接安装离合器（气动手轮机构）或安装支架。

Bottom mounting connection is designed in accordance with ISO5211 and DIN3337 standards for direct mounting with valve gear boxes or mounting brackets.

成套服务 Other Service

