

3PC BALL VALVE 1000 WOG UNION BUTT-WELDED



FEATURES

1000PSI / PN16~PN63

Size: 1/4"~3"

Materials: WCB, S.S.304(CF8), S.S.316(CF8M)

Full port, fully opening or closing

Blow-out proof stem, reliable sealing

Three pieces structure, easy operation and maintenance

PED97/23/EC (CE0035) approved

Investment casting approved to AD2000-WO certificate

Butt welded: ASME B16.25, DIN3239/PT1

Inspection & testing: API598, EN12266, DIN3230/3

Design: ASME B16.34

Applicable medium: water, oil, gas, corrosive liquids

Applicable temperature: -29°C~120°C (higher temperature is available upon request)

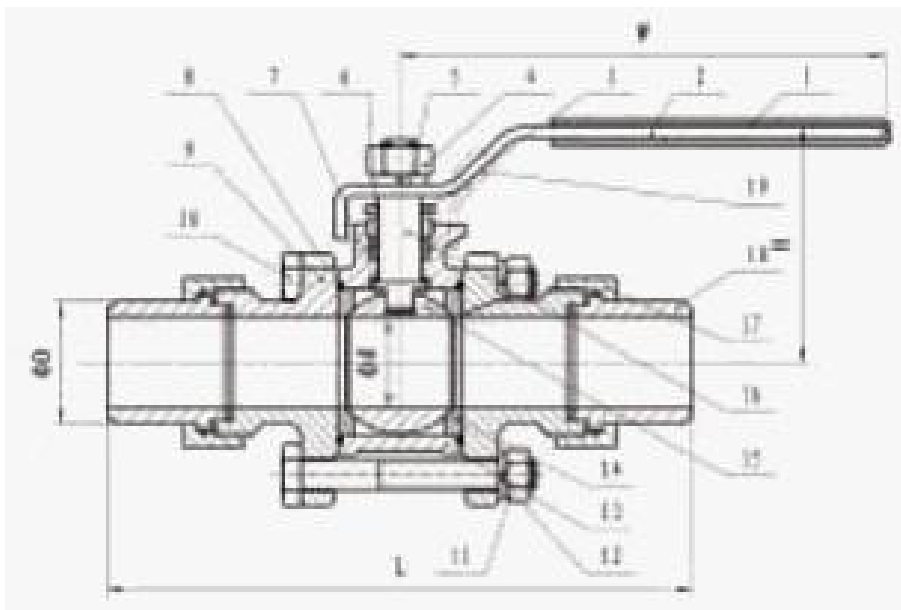

PARTS AND MATERIALS

ITEM	PART	MATERIAL
1	Handle cover	Plastic
2	Handle	SUS304
3	Gland nut	SUS304
4	Stem nut	SUS304
5	Spring washer	SUS304
6	Stem packing	PTFE
7	Stem seal	PTFE
8	Body seal	PTFE
9	Cap	WCB, CF8/CF8M,SS304,SS316
10	Bolt	SUS304
11	Nut	SUS304
12	Thrust washer	SUS304
13	Body	WCB, CF8/CF8M,SS304,SS316
14	Seat	RPTFE
15	Ball	CF8/CF8M,SS304,SS316
16	Stem	SUS304/SUS316
17	Nut	SUS304/SUS316
18	Sleeve	SUS304/SUS316
19	Locking device	SUS304

MAIN CONNECTION DIMENSIONS

SIZE	d	L	H	W
1/4"	12.5	165	48	105
3/8"	12.5	165	48	105
1/2"	15	178	50	105
3/4"	20	198	52	126
1"	25	224	65	144
1-1/4"	32	229	70	144
1-1/2"	38	249	85	189
2"	50	300	93	189
2-1/2"	65	338	116	224
3"	80	364	125	224

NOTES:

As we are constant endeavoring to improve the performance of our equipment.

The company reserves the right to make alteration from time to time and equipment differ from that detailed in this brochure.

