

3PC BALL VALVE 1000 WOG SOCKET WELDED



FEATURES

1000PSI / PN16~PN63

Size: 1/4"~4"

Materials: WCB, S.S.304(CF8), S.S.316(CF8M)

Full port, fully opening or closing

Blow-out proof stem, reliable sealing

Three pieces structure, easy operation and maintenance

PED97/23/EC (CE0035) approved

Investment casting approved to AD2000-WO certificate

Butt welded: ASME B16.25, DIN3239/PT1

Inspection & testing: API598, EN12266, DIN3230/3

Design: ASME B16.34

Applicable medium: water, oil, gas, corrosive liquids

Applicable temperature: -29°C~120°C (higher temperature is available upon request)

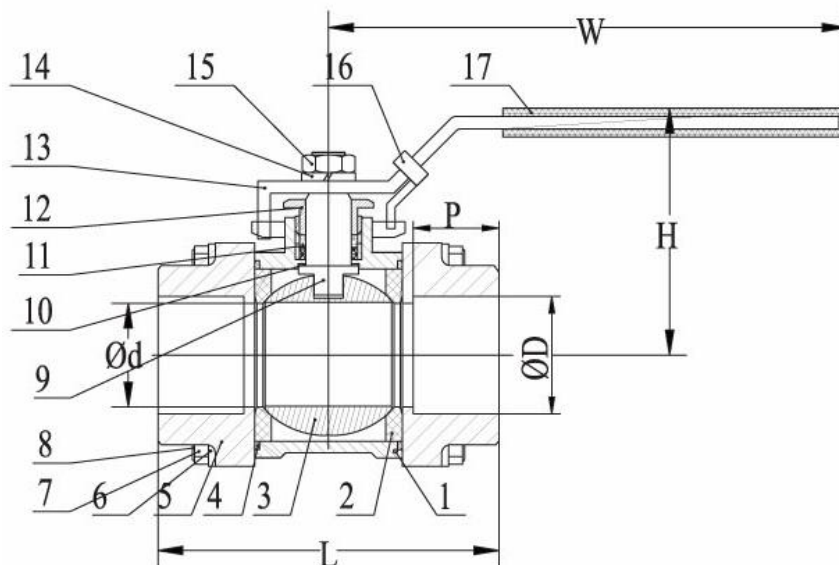

PARTS AND MATERIALS

ITEM	PART	MATERIAL
1	Body	WCB, CF8/CF8M,SS304,SS316
2	Ball seat	PTFE
3	Ball	CF8/CF8M,SS304,SS316
4	Body seal	PTFE
5	Cap	WCB, CF8/CF8M,SS304,SS316
6	Spring washer	SUS304
7	Nut	SUS304
8	Bolt	SUS304
9	Stem	SUS304/SUS316
10	Thrust washer	PTFE
11	Stem packing	PTFE
12	Gland nut	SUS304
13	Handle	SUS304
14	Stem packing	PTFE
15	Nut	SUS304
16	Lock device	SUS304
17	Handle cover	Plastic

MAIN CONNECTION DIMENSIONS

SIZE	d	L	H	W
1/4"	12.5	50.5	48	100
3/8"	12.5	50.5	48	100
1/2"	15	61.5	52	100
3/4"	20	70	61	127
1"	25	80	65	127
1-1/4"	32	93	79	154
1-1/2"	38	103	83	154
2"	50	125	90	192
2-1/2"	65	157.5	117	244
3"	76	179.5	144	244
4"	94	214	158	278

NOTES:

As we are constant endeavoring to improve the performance of our equipment.

The company reserves the right to make alteration from time to time and equipment differ from that detailed in this brochure.