

**3PC BALL VALVE 1000 WOG WELDED**



**FEATURES**

1000PSI / PN16~PN63

Size: 1/4"~4"

Materials: WCB, S.S.304(CF8), S.S.316(CF8M)

Full port, fully opening or closing

Blow-out proof stem, reliable sealing

Three pieces structure, easy operation and maintenance

PED97/23/EC (CE0035) approved

Investment casting approved to AD2000-WO certificate

Butt welded: ASME B16.25, DIN3239/PT1

Inspection & testing: API598, EN12266, DIN3230/3

Design: ASME B16.34

Applicable medium: water, oil, gas, corrosive liquids

Applicable temperature: -29°C~120°C (higher temperature is available upon request)

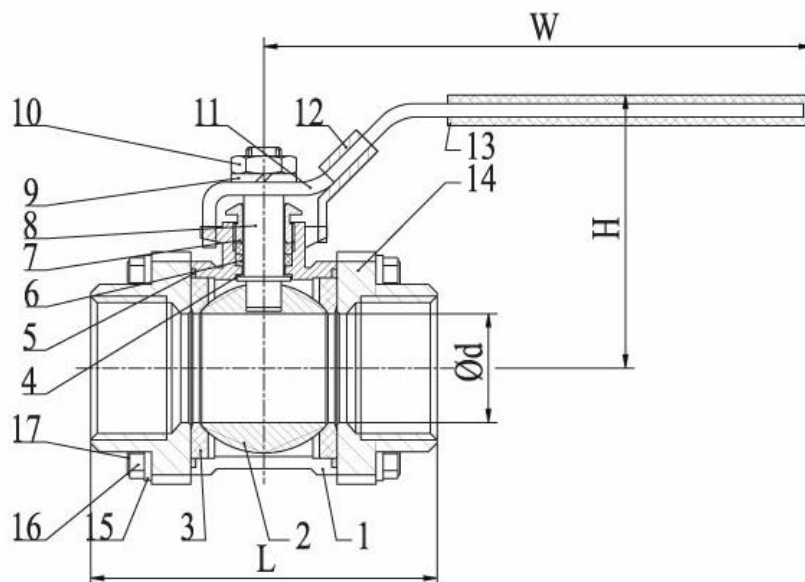

**PARTS AND MATERIALS**

ITEM	PART	MATERIAL
1	Body	WCB, CF8/CF8M,SS304,SS316
2	Ball	CF8/CF8M,SS304,SS316
3	Ball seat	RPTFE
4	Thrust washer	PTFE
5	Body gasket	PTFE
6	Stem packing	PTFE
7	Gland nut	SUS304
8	Stem	SUS304/SUS316
9	Spring washer	SUS304
10	Nut	SUS304
11	Handle	SUS304
12	Handle lock	SUS304
13	Handle cover	Plastic
14	Cap	WCB, CF8/CF8M,SS304,SS316
15	Spring washer	SUS304
16	Nut	SUS304
17	Bolt	SUS304

**MAIN CONNECTION DIMENSIONS**

SIZE	d	L	H	W
1/4"	11.6	51	43.5	103
3/8"	11.6	51	44.5	103
1/2"	15	62.5	50	103
3/4"	20	70.7	59	127
1"	25	79.6	61	127
1-1/4"	32	93.5	79	154
1-1/2"	38	103	83	154
2"	50	125.6	94	195
2-1/2"	65	158.2	135	244
3"	80	179.2	144	244
4"	100	212.5	149	285

**NOTES:**

As we are constant endeavoring to improve the performance of our equipment.

The company reserves the right to make alteration from time to time and equipment differ from that detailed in this brochure.

