

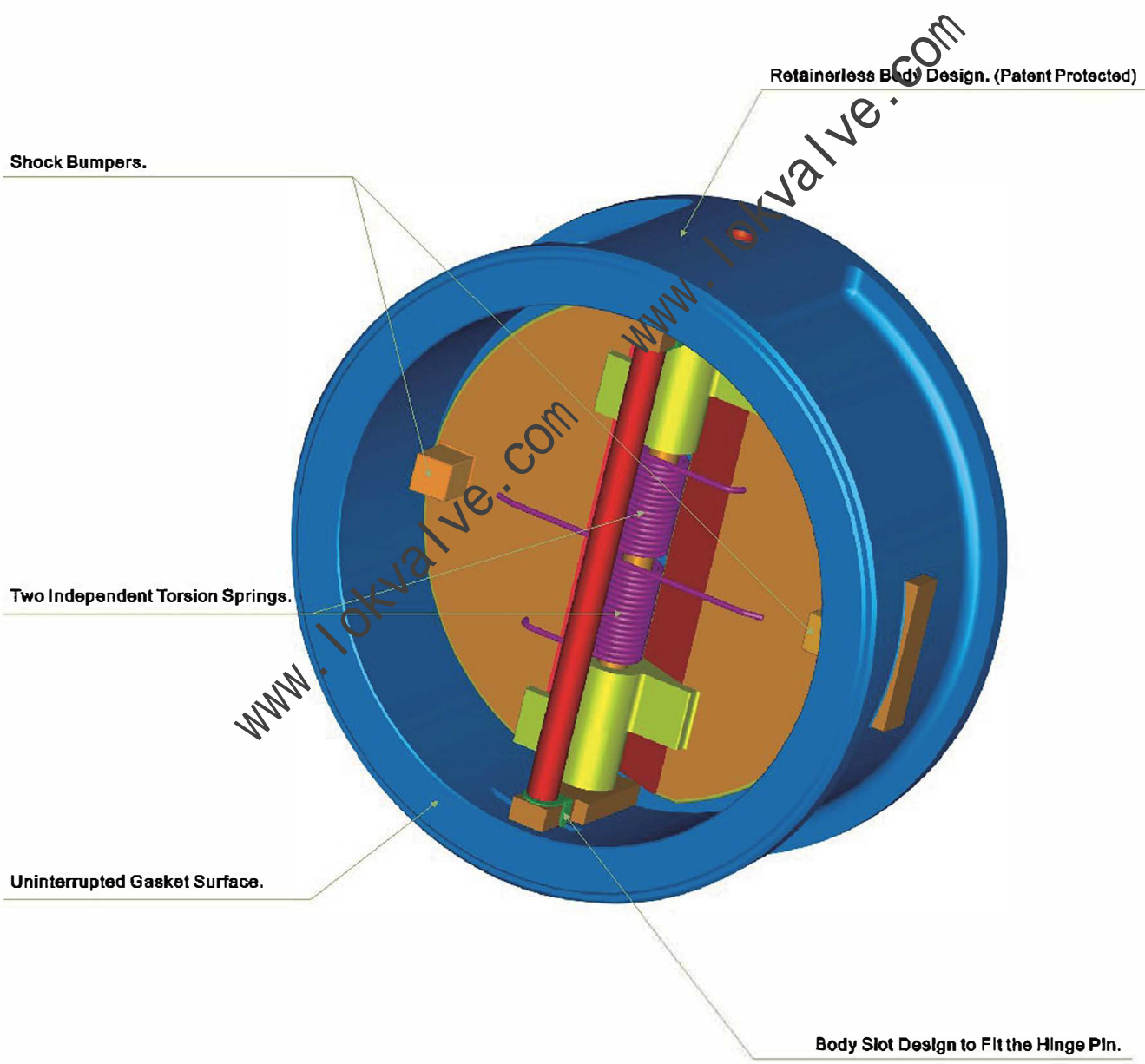

Dual plate wafer check valve has a shorter face-to-face dimension and dual plate design, the end connection options include wafer type, lug type and double-flange type, and are available in size from 2" to 60" and in pressure ratings from ASME class 150 through 2500. A wide range of body and trim materials are optional on customer's request. Compared to conventional swing check valves, NEWAY'S dual plate check valves have the advantage of zero leakage

toward outside (no bolted or threaded connections), cost savings, they can be installed in any line orientation, superior seal performance, offer minimal line shock, lower pressure loss and zero seat wear. This series of valves are widely used in oil & gas production, petroleum refining, petrochemical, pulp & paper, shipbuilding, and other fluid back flow prevention application.

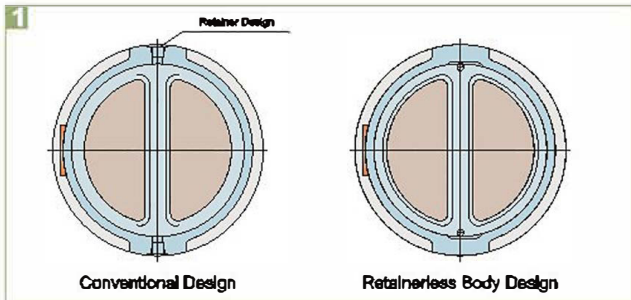



1 Retainerless Body Design (Patent Protected)

Dual plate valve bodies are a one-piece and short cylinder design with no holes through body wall, there is no need for external pins or plugs and no leakage toward outside. For critical service applications, such as hazardous or poisonous medium, this is a superior choice to minimize unwanted leakage to atmosphere.

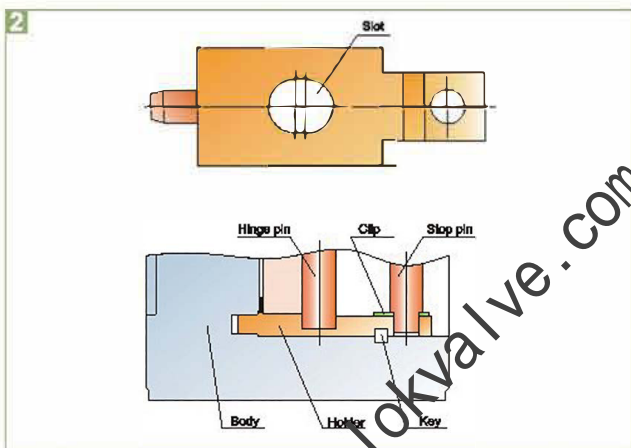

2 Body Slot Design to Fit the Hinge Pin

A body slot with carefully calculated clearance is designed to fit the hinge pin and allows hinge pin to move in the only direction of flow. The design eliminates the possibility of friction caused by the heel of the dual plate.

3. Shock bumpers

The integral cast bumper on the back of the dual plate is an effective design to prevent the frequent hitting, and reduces the pressing from the dual plate against the stop pin when the valve is fully opened. This extends the service life of the valve and minimizes

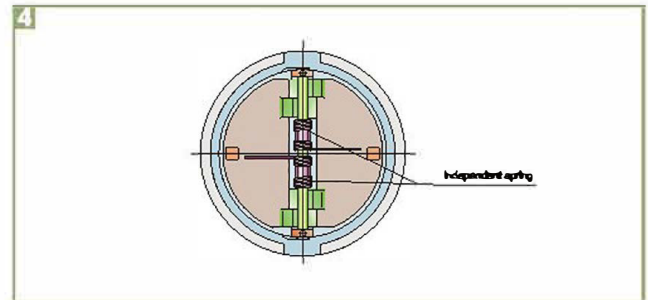

4 Two Independent Torsion Springs

Two high torsion springs ensure valve closure as quick as possible, and reduces water hammer, so as to extend valve life and improve system performance.

5. Uninterrupted Gasket Surface

The dual plate design incorporates an internal retention fitting. The fitting does not encroach the gasket sealing surface, to ensure the effective seal between valve and pipeline.

6. Light weight and compact wafer design

Dual plate wafer designs inherently makes this check valve lighter, which is only 10~25% of the weight of conventional swing check valve, to save money in initial valve cost and provides lower installation cost.

7. Flexibility in installation position

The spring feature aids in keeping the valve closed and the lighter weight in eliminating pipeline bending loads make the valve flexible installed in any position, to allow you to design your piping layout in the most efficient and least expensive method.

8. Dual plate & Flat seat design

When the valve opens, the heel of the dual plate is lifted in the direction of the flow, to avoid that the heel drag across the seating surface and cause wear. When closing the valve, both the two high torsion springs and the back pressure will force disc toe and heel back in turn to the flat seat to complete the seal.

9. Size Range

Due to features of the wafer check light weight, small installation space, spring aids and easy sealing, the valve may be used in the field of larger piping sizes, even in 60° or above piping system.

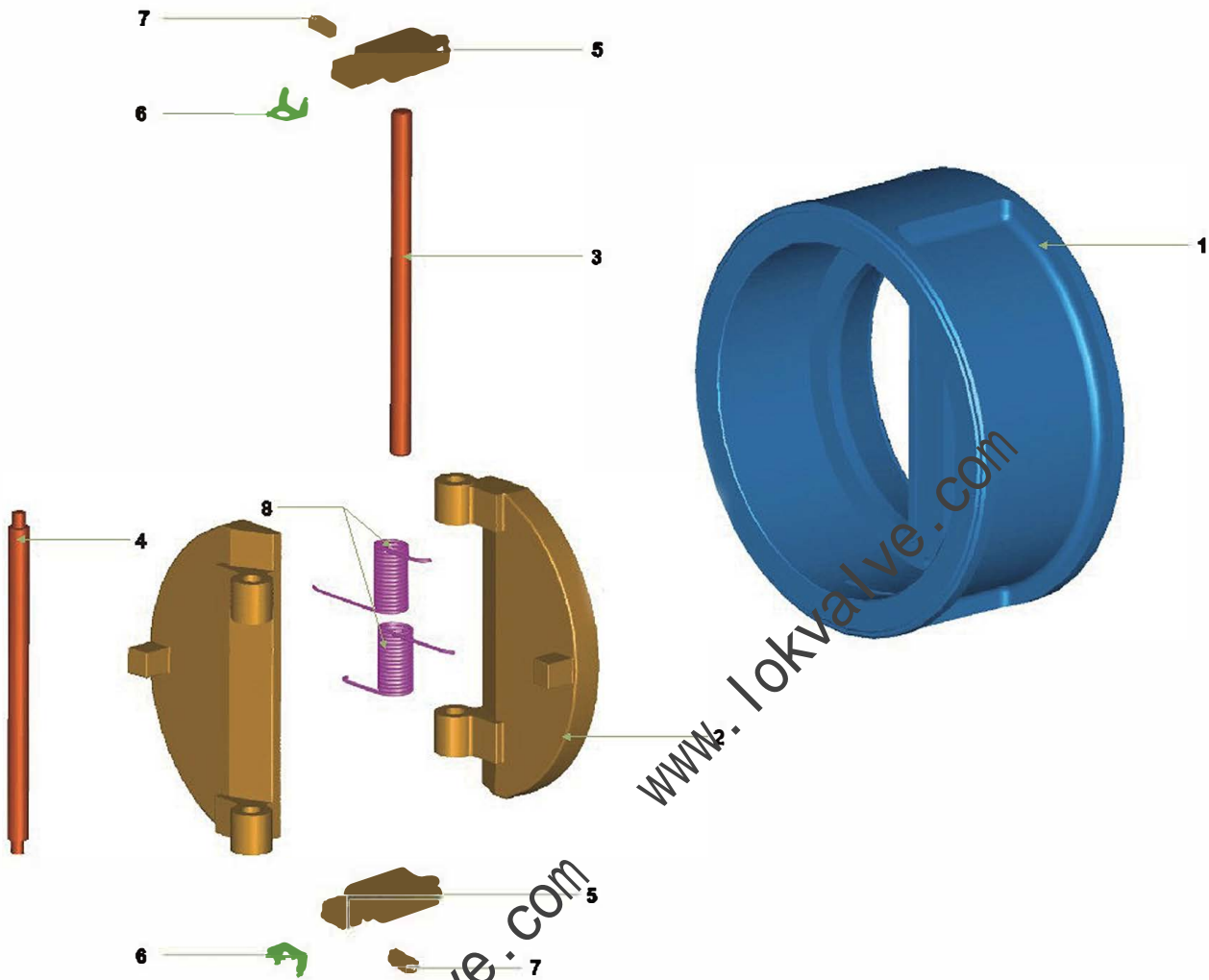

Materials

No.	Parts	Materials			
1	Body	ASTM A216-WCB/STL OVERLAY	ASTM A352-LCC/STL OVERLAY	ASTM A217-WC6/STL OVERLAY	ASTM A351 CF8M/STL OVERLAY
2	Disc	ASTM A217-CA15 or ASTM A216-WCB/CR13 OVERLAY	ASTMA351-CF8M or ASTMA352-LCC/316 OVERLAY	ASTM A217-WC6/STL OVERLAY	ASTMA351 CF8M
3	Hinge pin	ASTM A276-410	ASTM A276-316	ASTM A276-410	ASTM A276-316
4	Stop pin	ASTM A276-410	ASTM A276-316	ASTM A276-410	ASTM A276-316
5	Holder	ASTM A276-420	ASTM A276-316	ASTM A276-420	ASTM A276-316
6	Clip	304S.S	316S.S	316S.S	316S.S
7	Key	ASTM A182-F304	ASTM A182-F316	ASTMA182-F304	ASTMA182-F316
8	Spring	INCONEL X-750	INCONEL X-750	INCONEL X-750	INCONEL X-750
9	Hook screw (5" & larger)	AISI 1025	AISI 1025	AISI 1025	304S.S

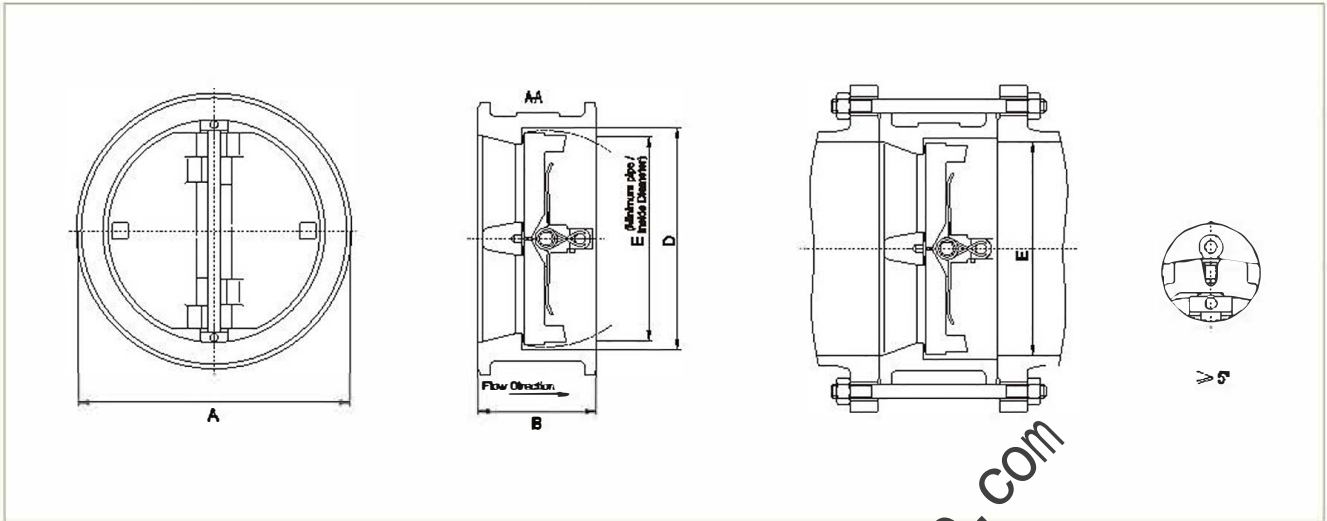

Wafer type

Wafer Type - ASME Class 150

Size		Dimensions								Stud details				End facing	Hook screw hole size		Weight		
		A		B		D		E		No.	Diameter		RF Stud length		In	mm	lbs	kg	
NPS	DN	In	mm	In	mm	In	mm	In	mm		In	mm	In	mm					In
2"	50	4.09	104	2.38	60	2.36	60	2.01	51	4	0.63	16	5.75	146	RF	-	-	6	3
2 1/2"	65	4.84	123	2.63	67	2.88	73	2.34	60	4	0.63	16	6.25	159	RF	-	-	11	5
3"	80	5.35	136	2.88	73	2.87	73	2.91	74	4	0.63	16	6.75	171	RF	-	-	11	5
4"	100	6.85	174	2.88	73	4.49	114	3.83	97	8	0.63	16	6.75	171	RF	-	-	18	8
5"	125	7.72	196	3.38	86	5.56	141	4.87	122	8	0.75	19	7.50	191	RF	-	-	28	13
6"	150	8.70	221	3.88	98	6.61	168	5.77	146	8	0.75	19	8.00	203	RF	0.50	13	31	14
8"	200	10.94	278	5.00	127	8.62	219	7.63	194	8	0.75	19	9.50	241	RF	0.50	13	57	26
10"	250	13.35	339	5.75	146	10.75	273	8.56	243	12	0.88	22	10.50	267	RF	0.50	13	98	45
12"	300	16.06	406	7.19	181	12.76	324	11.36	269	12	0.88	22	12.25	311	RF	0.75	19	140	64
14"	350	17.68	449	7.26	184	14.02	356	12.50	318	12	1.00	25	12.75	324	RF	0.75	19	170	77
16"	400	20.12	511	7.50	191	15.98	406	15.00	381	16	1.13	29	13.25	337	RF	1.00	25	230	104
18"	450	21.63	549	8.00	203	18.00	457	16.88	429	16	1.13	29	14.25	362	RF	1.00	25	270	123
20"	500	23.68	606	8.63	219	20.00	506	18.81	478	20	1.25	32	15.25	387	RF	1.00	25	360	163
24"	600	26.25	718	8.75	222	24.00	610	22.63	575	20	1.25	32	16.00	406	RF	1.00	25	480	218
28"	650	30.50	776	14.00	356	26.00	660	24.25	616	24	1.25	32	23.25	591	RF	1.00	25	1000	454
28"	700	32.75	832	15.00	381	28.00	711	-	-	28	1.25	32	24.50	622	RF	1.00	25	1200	544
30"	750	34.75	883	12.00	305	30.00	762	29.25	743	28	1.25	32	21.75	552	RF	1.00	25	1000	454
32"	800	37.00	940	14.00	356	32.00	813	-	-	28	1.50	38	24.75	629	RF	1.00	25	1400	635
36"	900	41.25	1048	14.50	368	36.00	914	35.00	869	32	1.50	38	28.00	680	RF	1.00	25	1750	794
40"	1000	45.75	1162	17.00	432	40.00	1016	-	-	36	1.50	38	28.50	724	RF	1.50	38	2600	1179
42"	1050	48.00	1219	17.00	432	42.00	1067	41.00	1041	36	1.50	38	29.00	737	RF	1.50	38	2850	1293
48"	1200	54.50	1384	20.63	524	48.00	1219	47.00	1194	44	1.50	38	31.00	787	RF	1.50	38	4400	1998
54"	1350	61.00	1549	23.25	591	54.00	1372	51.50	1308	44	1.75	44	35.75	909	RF	1.50	38	6500(2)	2495(2)
60"	1500	67.50	1715	28.00	680	60.00	1524	56.00	1422	52	1.75	44	38.75	984	RF	1.50	38	7200(2)	3268(2)

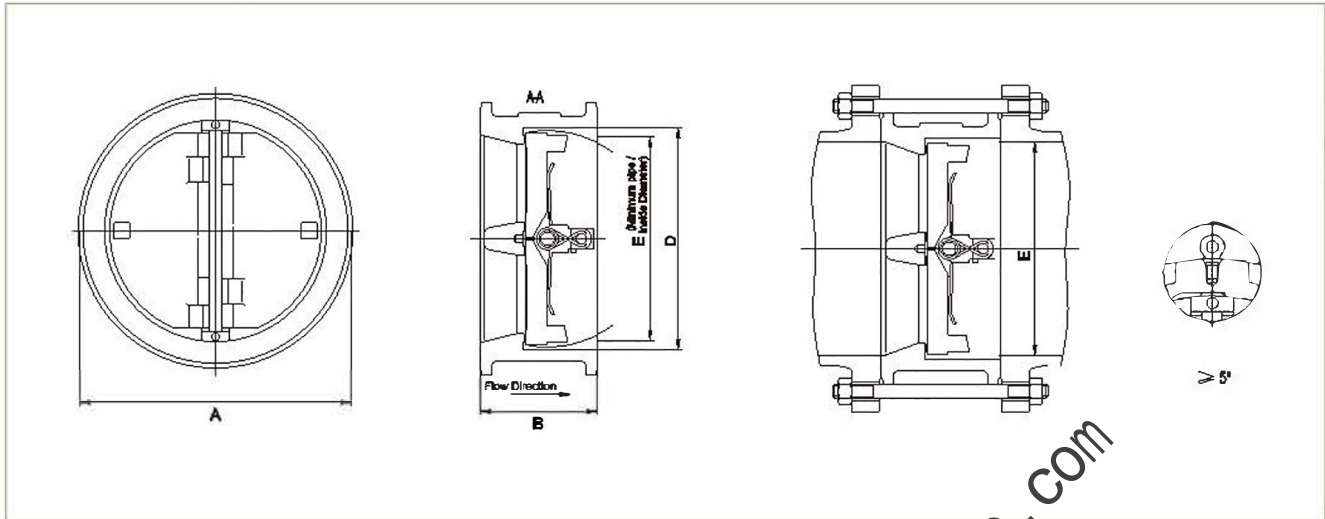

Wafer type

Wafer Type - ASME Class 300

Size		Dimensions								Stud details				End screws	Hook screw hole size		Weight		
		A		B		D		E		No.	Pitch		In		mm	lbs	kg		
NPS	DN	In	mm	In	mm	In	mm	In	mm		In	mm		In				mm	In
2"	50	4.37	111	2.38	60	2.52	64	2.01	51	8	0.63	16	6.00	152	RF	-	-	6.5	3
2 1/2"	65	5.08	129	2.63	67	2.88	73	2.34	60	8	0.75	19	6.75	171	RF	-	-	13	6
3"	80	5.87	149	2.88	73	3.70	94	2.91	71	8	0.75	19	7.25	184	RF	-	-	13	6
4"	100	7.09	180	2.88	73	4.65	118	3.83	97	8	0.75	19	7.50	191	RF	-	-	18	8
5"	125	8.46	215	3.38	86	5.58	141	4.67	122	8	0.75	19	8.25	210	RF	-	-	28	13
6"	150	9.84	250	3.88	98	6.77	172	5.77	146	12	0.75	19	9.00	229	RF	0.50	13	40	18
8"	200	12.13	308	5.00	127	8.74	222	7.83	194	12	0.88	22	10.75	273	RF	0.50	13	68	31
10"	250	14.17	360	5.75	146	10.63	275	9.58	243	18	1.00	25	12.25	311	RF	0.50	13	110	50
12"	300	16.57	421	7.13	181	12.41	326	11.38	299	16	1.13	29	14.25	362	RF	0.75	19	170	77
14"	350	19.06	484	8.75	222	14.09	368	12.50	318	20	1.13	29	16.00	406	RF	0.75	19	290	132
16"	400	21.18	538	9.13	232	18.06	408	14.31	364	20	1.25	32	17.00	432	RF	1.00	25	400	181
18"	450	23.50	597	10.38	264	18.00	457	16.88	429	24	1.25	32	18.50	470	RF	1.00	25	620	236
20"	500	25.75	654	11.50	292	20.00	508	17.94	456	24	1.25	32	20.00	508	RF	1.00	25	700	318
24"	600	30.50	775	12.50	318	24.00	610	21.56	548	24	1.50	38	22.00	559	RF	1.00	25	1050	476
26"	650	32.88	835	14.00	356	26.00	660	24.38	619	28	1.63	41	25.00	635	RF	1.00	25	1250	587
28"	700	35.38	899	15.00	381	28.00	711	-	-	28	1.63	41	26.50	673	RF	1.00	25	1600	680
30"	750	37.50	953	14.50	368	30.00	762	28.75	730	28	1.75	44	26.75	679	RF	1.00	25	1650	748
32"	800	39.63	1006	16.00	406	32.00	813	-	-	28	1.88	48	29.00	737	RF	1.00	25	2000	907
36"	900	44.00	1118	19.00	483	36.00	914	35.00	889	32	2.00	51	32.75	832	RF	1.00	25	2700	1225
40"	1000	43.88	1114	21.50	546	36.00	914	-	-	32	1.63	41	35.25	895	RF	1.50	38	3400	1542
42"	1050	45.88	1165	22.38	568	40.00	1018	41.00	1041	32	1.63	41	36.50	927	RF	1.50	38	4200	1905
48"	1200	52.13	1324	24.75	629	44.00	1118	47.00	1194	32	1.88	48	40.80	1029	RF	1.50	38	7350	3334

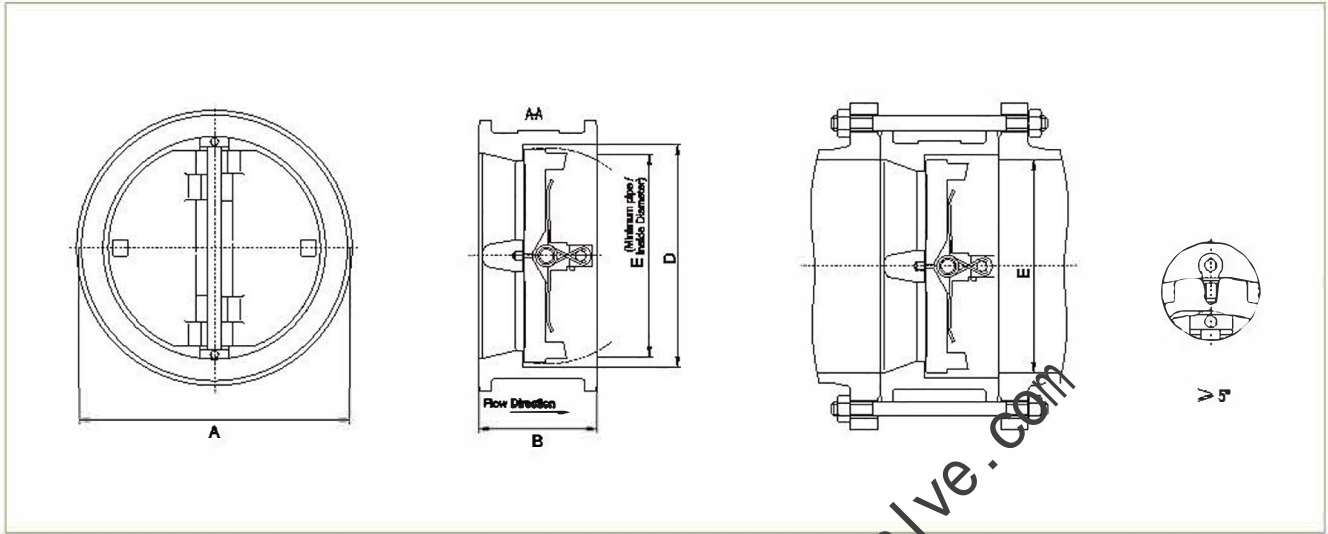

Wafer type

Wafer Type - ASME Class 600

Size		Dimensions								No.	Stud details						End facing	Hook screw hole size		Weight	
		A		B		D		E			Diameter		RF Stud length		RFJ Stud length			in	mm	lbs	kg
NPS	DN	in	mm	in	mm	in	mm	in	mm		in	mm	in	mm	in	mm					
2"	60	4.38	111	2.38	60	2.62	64	2.01	61	8	0.63	16	6.60	166	7.00	178	RF/RTJ#23	-	-	6.5	3
3"	80	5.63	148	2.88	73	3.70	94	2.91	74	8	0.75	19	7.75	197	8.25	210	RF/RTJ#31	-	-	13	6
4"	100	7.63	194	3.13	79	4.65	118	3.83	97	8	0.88	22	8.75	222	9.25	235	RF/RTJ#37	-	-	24	11
6"	150	10.50	267	5.38	137	6.69	168	5.77	148	12	1.00	25	12.00	305	12.75	324	RF/RTJ#45	0.50	13	69	31
8"	200	12.63	321	6.60	166	7.63	193	7.83	194	12	1.13	29	14.26	362	14.75	375	RF/RTJ#49	0.50	13	116	53
10"	250	15.75	400	8.38	213	10.75	273	9.56	243	18	1.25	32	17.00	432	17.60	445	RF/RTJ#53	0.50	13	210	95
12"	300	18.00	457	9.00	229	12.75	324	11.38	289	20	1.25	32	17.75	451	18.25	464	RF/RTJ#57	0.75	19	300	136
14"	350	19.38	492	10.75	273	14.00	356	12.50	318	20	1.38	35	20.26	514	20.75	527	RF/RTJ#61	0.75	19	430	195
16"	400	22.26	565	12.00	306	16.00	406	14.31	364	20	1.50	38	22.25	565	22.75	578	RF/RTJ#65	1.00	26	600	295
16"	450	24.13	613	14.25	362	18.00	457	16.13	410	20	1.63	41	25.26	641	26.75	664	RF/RTJ#69	1.00	26	800	366
20"	500	26.88	683	14.50	368	20.00	508	17.94	456	24	1.63	41	26.00	660	26.75	679	RF/RTJ#73	1.00	25	1125	510
24"	600	31.13	791	17.25	438	24.00	610	21.56	548	24	1.63	41	29.75	756	30.75	781	RF/RTJ#77	1.00	25	1750	794
26"	650	34.13	867	18.00	457	26.00	680	24.00	610	28	1.68	46	31.75	806	32.75	832	RF/RTJ#93	1.00	25	1950	885
26"	700	36.00	914	19.00	483	28.00	711	-	-	28	2.00	51	33.26	846	34.26	870	RF/RTJ#94	1.00	26	2300	1043
30"	750	38.25	972	19.88	505	30.00	762	28.75	730	28	2.00	51	34.26	870	35.25	895	RF/RTJ#95	1.00	25	2850	1283
32"	800	40.25	1022	21.00	533	32.00	813	-	-	28	2.25	57	36.25	921	37.25	946	RF/RTJ#96	1.00	25	3200	1452
36"	900	44.50	1130	25.00	635	38.00	914	33.75	857	28	2.50	64	41.25	1048	42.50	1080	RF/RTJ#98	1.00	25	4700	2132
40"	1000	45.50	1158	26.00	660	38.00	914	-	-	32	2.25	57	44.00	1130	-	-	RF	1.60	a	5200	2369
42"	1060	48.00	1219	27.60	701	38.00	965	39.60	1003	28	2.60	64	47.26	1200	-	-	RF	1.50	38	6000	2722

Wafer Type - ASME Class 900

Size		Dimensions								Stud details						End facing	Hook screw hole size		Weight		
		A		B		D		E		No.	Diameter		RF Stud length		RFJ Stud length		In	mm	lbs	kg	
NPS	DN	In	mm	In	mm	In	mm	In	mm		In	mm	In	mm	In	mm					In
2"	50	5.63	143	2.75	70	2.38	60	1.88	43	8	0.88	22	8.50	216	8.75	222	RF/RT.#24	-	-	11.5	3
3"	80	6.63	168	3.25	83	2.91	74	2.83	67	8	0.88	22	8.50	216	9.00	229	RF/RT.#31	-	-	21	10
4"	100	8.13	206	4.00	102	4.50	114	3.44	87	8	1.13	29	10.25	260	10.75	273	RF/RT.#37	0.38	10	43	20
6"	150	11.38	289	6.25	159	6.63	168	5.19	132	12	1.13	29	13.25	337	13.75	349	RF/RT.#45	0.50	13	125	57
8"	200	14.13	359	8.13	206	8.63	219	6.81	173	12	1.38	35	16.25	413	16.75	426	RF/RT.#49	0.50	13	278	126
10"	250	17.13	435	9.50	241	10.76	273	8.50	216	16	1.38	35	18.50	470	18.75	476	RF/RT.#53	0.50	13	400	181
12"	300	19.63	498	11.50	292	12.76	324	10.13	257	20	1.38	35	20.75	527	21.25	640	RF/RT.#67	0.76	19	450	204
14"	350	20.60	521	14.00	356	14.00	366	11.50	292	20	1.60	38	23.75	603	14.50	622	RF/RT.#62	0.76	19	700	318
16"	400	22.83	575	15.13	384	16.00	406	12.81	325	20	1.83	41	26.50	648	26.25	667	RF/RT.#66	1.00	25	960	431
18"	450	25.13	638	17.76	451	18.00	457	14.44	367	20	1.88	48	29.25	743	30.00	732	RF/RT.#70	1.00	25	1400	638
20"	500	27.60	699	17.76	451	20.00	508	17.94	456	20	2.00	51	30.00	762	31.00	767	RF/RT.#74	1.00	25	1650	748
24"	600	33.00	838	19.50	495	24.00	610	21.50	546	20	2.50	64	33.75	887	35.00	889	RF/RT.#78	1.00	25	2325	1066

Wafer Type - ASME Class 1500

Size		Dimensions								Stud details						End facing	Hook hole		Weight		
		A		B		D		E		No.	Diameter		RF Stud len		RFJ Stud length		In	mm	lbs	kg	
NPS	DN	In	mm	In	mm	In	mm	In	mm		In	mm	In	mm	In	mm					In
2"	50	5.63	143	2.75	70	2.38	60	1.88	43	8	0.88	22	8.50	216	8.75	222	RF/RT.#24	-	-	11.5	5
3"	80	6.88	175	3.25	83	2.91	74	2.63	67	8	1.13	29	10.25	260	10.50	267	RF/RT.#35	-	-	23	10
4"	100	8.25	210	4.00	102	4.50	114	3.44	87	8	1.25	32	11.75	296	12.00	305	RF/RT.#39	0.38	10	45	20
6"	150	11.13	283	6.25	159	6.63	168	5.19	132	12	1.38	35	16.50	419	17.00	432	RF/RT.#46	0.50	13	125	57
8"	200	13.88	352	8.13	206	8.63	219	6.81	173	12	1.63	41	19.75	502	20.50	521	RF/RT.#50	0.50	13	275	125
10"	250	17.13	435	9.75	241	10.75	273	8.50	216	12	1.88	48	23.25	591	23.75	603	RF/RT.#54	0.50	13	450	195
12"	300	20.50	521	12.00	305	12.75	324	10.13	267	16	2.00	51	27.00	686	28.00	711	RF/RT.#58	0.75	19	700	318
14"	350	22.75	578	14.00	356	14.00	366	11.50	292	16	2.25	57	30.25	768	31.50	800	RF/RT.#63	0.75	19	925	420
16"	400	26.25	641	15.13	384	16.00	406	12.81	325	16	2.50	64	32.75	832	34.25	870	RF/RT.#67	1.00	25	1300	590
18"	450	27.75	705	18.44	469	18.00	457	13.75	349	16	2.75	70	38.00	965	39.50	1003	RF/RT.#71	1.00	25	1900	862
20"	500	29.75	758	21.00	533	20.00	508	14.75	375	16	3.00	76	42.25	1073	44.00	1118	RF/RT.#75	1.00	25	2600	1179
24"	600	35.50	902	22.00	559	24.00	610	15.13	384	16	3.60	89	46.25	1175	48.50	1232	RF/RT.#79	1.00	25	3725	1690

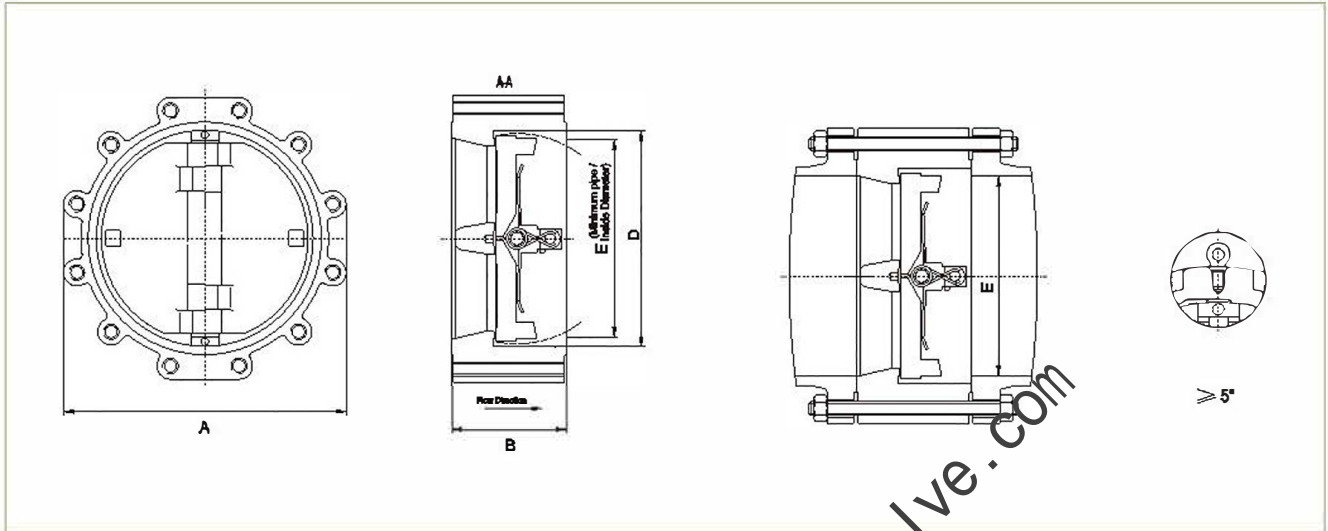

Lug type

Lug Type - ASME Class 150

Size		Dimensions								Stud details				End facing	Hook screw hole size		Weight		
		A		B		D		E		No.	Diameter		RF Stud length		In	mm	lbs	kg	
NPS	DN	In	mm	In	mm	In	mm	In	mm		In	mm	In	mm					
2"	50	8.00	152	2.38	60	2.38	60	2.01	51	4	0.83	16	2.75	70	RF	-	-	9	4
2 1/2"	65	7.00	178	2.63	67	2.68	73	2.34	60	4	0.83	16	2.75	70	RF	-	-	24	11
3"	80	7.20	191	2.88	73	2.87	73	2.51	74	4	0.83	16	3.00	78	RF	-	-	18	8
4"	100	9.00	229	2.88	73	4.49	114	3.83	97	8	0.83	16	3.00	76	RF	-	-	33	15
5"	125	10.00	254	3.38	86	5.58	143	4.87	122	8	0.75	19	3.25	83	RF	-	-	53	24
6"	150	11.00	279	3.88	98	6.81	168	5.77	146	8	0.75	19	3.25	83	RF	0.50	13	63	24
8"	200	13.50	343	5.00	127	8.02	219	7.63	194	8	0.75	19	3.50	89	RF	0.50	13	130	59
10"	250	16.00	406	6.75	165	10.75	273	9.98	243	12	0.88	22	3.75	95	RF	0.50	13	216	98
12"	300	19.00	483	7.13	181	12.76	324	11.38	289	12	0.88	22	3.75	95	RF	0.75	19	270	123
14"	350	21.00	533	7.87	184	14.02	356	12.50	318	12	1.00	25	4.25	108	RF	0.75	19	330	160
16"	400	23.50	597	7.50	191	15.98	408	15.00	381	16	1.00	29	4.25	108	RF	1.00	25	420	191
18"	450	25.00	635	8.00	203	18.00	457	16.88	429	16	1.13	29	4.75	121	RF	1.00	25	500	227
20"	500	27.50	699	8.83	219	20.00	508	18.81	478	20	1.13	32	5.00	127	RF	1.00	25	850	295
24"	600	32.00	813	8.75	222	24.00	610	22.63	576	20	1.25	32	6.50	140	RF	1.00	25	860	386
26"	650	34.25	870	14.00	356	28.00	660	24.25	616	24	1.25	32	6.50	165	RF	1.00	25	1900	728
28"	700	36.50	927	15.00	381	28.00	711	-	-	28	1.25	32	6.50	166	RF	1.00	25	1900	882
30"	750	38.75	984	12.00	305	30.00	782	29.25	743	28	1.25	32	6.75	171	RF	1.00	25	1700	771
32"	800	41.75	1060	14.00	386	32.00	813	-	-	28	1.50	38	7.50	191	RF	1.00	25	2400	1089
36"	900	48.00	1308	14.50	368	38.00	914	35.00	888	32	1.50	38	8.00	203	RF	1.00	25	2800	1270
40"	1000	50.75	1289	17.00	432	40.00	1016	-	-	36	1.50	38	8.00	203	RF	1.50	38	4100	1860
42"	1050	58.00	1348	17.00	432	42.00	1067	41.00	1041	36	1.50	38	8.25	210	RF	1.50	38	4400	1986
48"	1200	59.50	1611	20.83	524	48.00	1219	47.00	1194	44	1.50	38	8.75	222	RF	1.50	38	6600	2994
54"	1350	66.25	1683	23.25	591	54.00	1372	51.50	1308	44	1.75	44	9.75	248	RF	1.50	38	8300 ⁽²⁾	3765 ⁽²⁾
60"	1500	73.00	1854	26.00	660	60.00	1624	56.00	1422	52	1.75	44	10.25	260	RF	2.00	51	10700 ⁽²⁾	4853 ⁽²⁾

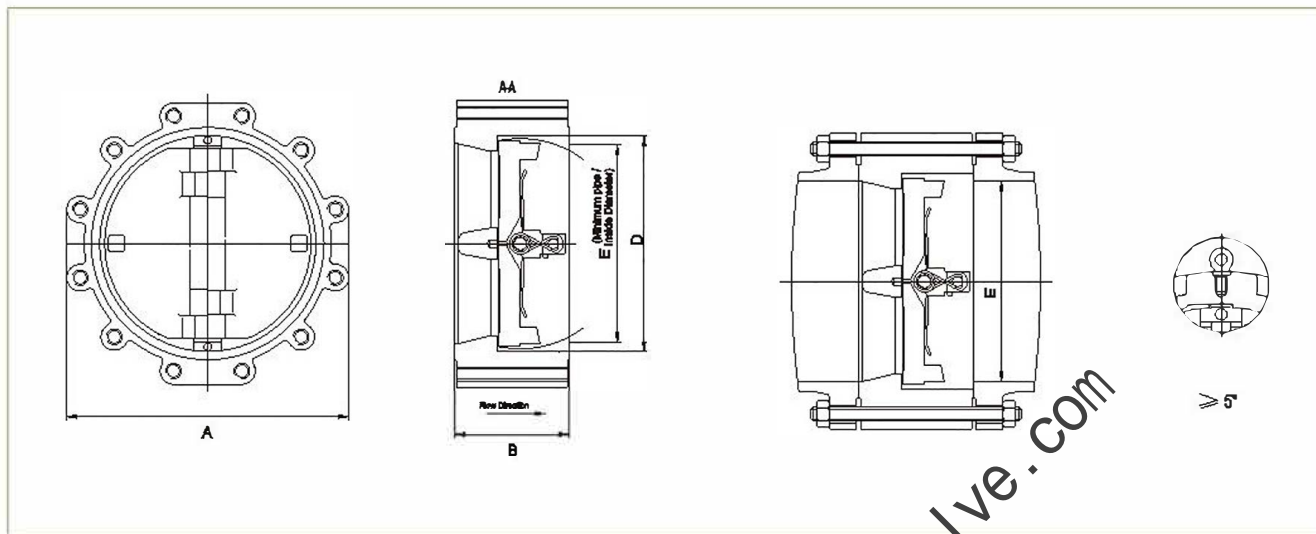

Lug type

Lug Type - ASME Class 300

Size		Dimensions								Stud details				End facing	Hook screw hole size		Weight		
		A		B		D		E		No.	Diameter		RF Stud length		In	mm	lbs	kg	
NPS	DN	In	mm	In	mm	In	mm	In	mm		In	mm	In	mm					
2"	50	6.50	165	2.38	60	2.52	64	2.01	51	8	0.83	16	2.75	70	RF	-	-	18	8
2 1/2"	65	7.50	191	2.63	67	2.68	73	2.34	60	8	0.75	19	3.25	83	RF	-	-	28	12
3"	80	8.25	210	2.88	73	3.70	94	2.91	74	8	0.75	19	3.50	89	RF	-	-	33	15
4"	100	10.00	254	2.88	73	4.65	118	3.63	97	8	0.75	19	3.50	89	RF	-	-	55	25
5"	125	11.00	279	3.38	88	6.06	141	4.87	122	8	0.75	19	3.75	95	RF	-	-	70	32
6"	150	12.50	318	3.88	98	8.77	172	5.77	146	12	0.75	19	3.75	95	RF	0.50	13	90	45
6"	200	15.00	381	5.00	127	8.74	222	7.63	194	12	0.88	22	4.26	108	RF	0.60	13	143	66
10"	250	17.50	445	5.75	146	10.63	275	9.56	248	16	1.00	25	4.75	121	RF	0.50	13	233	108
12"	300	20.60	521	7.13	181	12.91	328	11.38	288	16	1.13	29	5.26	133	RF	0.75	19	350	169
14"	350	23.00	584	8.75	222	14.09	358	12.50	318	20	1.13	29	5.25	133	RF	0.75	19	550	250
16"	400	25.60	648	9.13	232	16.06	408	14.31	364	20	1.26	32	5.76	146	RF	1.00	25	750	340
18"	450	28.00	711	10.38	264	18.00	457	16.88	428	24	1.25	32	6.00	152	RF	1.00	25	890	431
20"	500	30.60	775	11.60	292	20.00	508	17.94	458	24	1.26	32	6.00	162	RF	1.00	25	1250	667
24"	600	36.00	914	12.50	318	24.00	610	21.58	548	24	1.50	38	7.00	178	RF	1.00	25	1850	839
26"	650	36.26	972	14.00	356	26.00	660	24.38	619	28	1.83	41	7.76	197	RF	1.00	25	2200	998
28"	700	40.75	1035	15.00	381	28.00	711	-	-	28	1.83	41	8.25	210	RF	1.00	25	2700	1225
30"	750	43.00	1092	14.60	368	30.00	762	28.76	730	28	1.76	44	8.76	222	RF	1.00	25	2800	1270
32"	800	45.25	1149	16.00	408	32.00	813	-	-	28	1.88	48	9.25	235	RF	1.00	25	3400	1542
36"	900	50.00	1270	19.00	483	36.00	914	35.00	889	32	2.00	51	9.76	248	RF	1.00	25	4600	2067
40"	1000	58.75	1238	21.50	546	36.00	914	-	-	32	1.83	41	9.25	235	RF	1.50	38	5100	2313
42"	1050	50.76	1289	22.38	568	40.00	1016	41.00	1041	32	1.83	41	9.50	241	RF	1.50	38	6100	2767
48"	1200	57.75	1467	24.75	629	44.00	1118	47.00	1194	32	1.88	48	10.50	267	RF	1.50	38	10000	4536

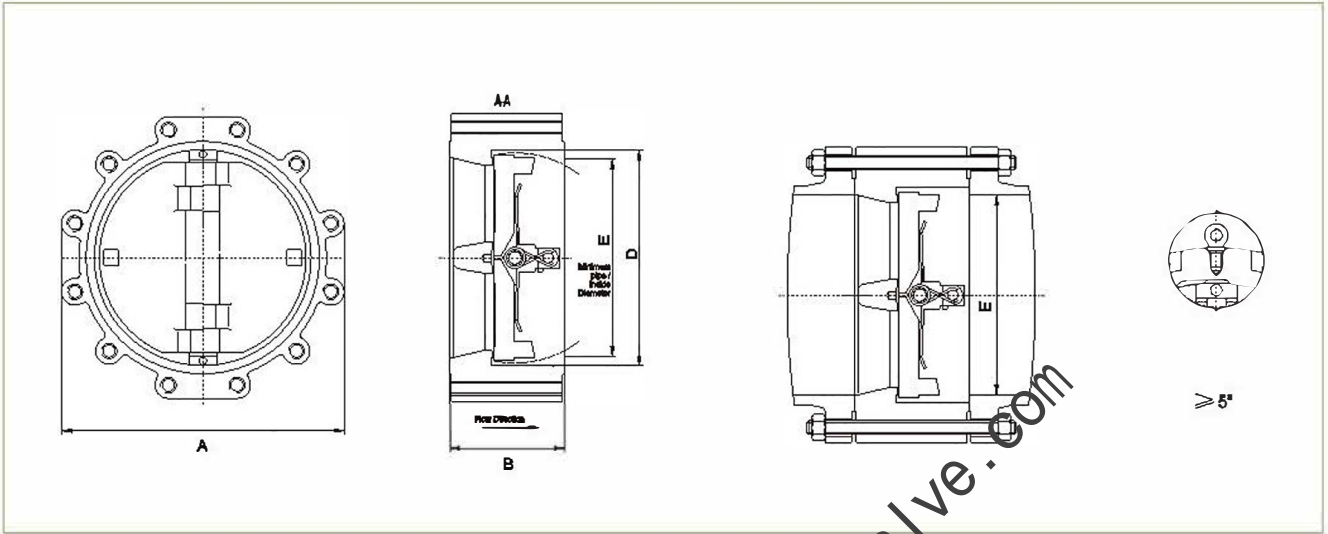

Lug type

Lug Type - ASME Class 600

Size		Dimensions								Stud details						End facing	Hook screw hole size		Weight		
		A		B		D		E		No.	Diameter		RF Stud length		RFJ Stud length		in	mm	lbs	kg	
NPS	DN	in	mm	in	mm	in	mm	in	mm		in	mm	in	mm	in	mm					in
2"	50	6.50	165	2.38	60	2.52	64	2.01	51	8	0.63	16	3.25	83	3.75	95	RF/RTJ#23	-	-	18	8
3"	80	8.25	210	2.88	73	3.70	94	2.91	74	8	0.75	19	3.75	95	4.26	108	RF/RTJ#31	-	-	33	15
4"	100	10.75	273	3.13	79	4.65	118	3.83	97	8	0.89	22	4.25	108	4.75	121	RF/RTJ#37	-	-	86	39
6"	150	14.00	356	5.38	137	6.63	168	5.27	146	12	1.00	25	5.00	127	5.50	140	RF/RTJ#45	0.50	13	172	78
8"	200	16.50	419	6.50	165	8.63	219	7.33	194	12	1.13	29	5.75	146	6.00	152	RF/RTJ#49	0.50	13	312	142
10"	250	20.00	508	8.38	213	10.75	273	9.56	243	16	1.26	32	6.25	159	6.75	171	RF/RTJ#53	0.50	13	515	234
12"	300	22.00	559	9.00	229	12.75	324	11.38	289	20	1.26	32	6.50	165	6.75	171	RF/RTJ#57	0.75	19	560	250
14"	350	23.75	603	10.75	273	14.00	356	12.60	318	20	1.38	35	6.75	171	7.26	184	RF/RTJ#61	0.75	19	800	363
16"	400	27.00	688	12.00	305	16.00	406	14.31	364	20	1.50	38	7.50	191	7.76	197	RF/RTJ#66	1.00	25	1150	522
18"	450	29.25	743	14.25	362	18.00	457	16.13	410	20	1.63	41	8.00	203	8.50	216	RF/RTJ#69	1.00	25	1500	703
20"	500	32.00	813	14.50	368	20.00	508	17.94	466	24	1.63	41	8.26	210	9.00	229	RF/RTJ#73	1.00	25	1900	862
24"	600	37.00	940	17.25	438	24.00	610	21.86	648	24	1.63	41	8.76	222	9.50	241	RF/RTJ#77	1.00	25	3000	1361
26"	660	40.00	1016	18.00	457	26.00	660	24.00	610	28	1.88	48	9.50	241	10.50	267	RF/RTJ#83	1.00	25	3400	1542
28"	700	42.25	1073	19.00	483	28.00	711	-	-	28	2.00	51	10.00	254	11.00	279	RF/RTJ#84	1.00	25	4000	1814
30"	750	44.60	1130	19.88	606	30.00	762	28.76	730	28	2.00	51	10.26	260	11.26	286	RF/RTJ#86	1.00	25	4700	2132
32"	800	47.00	1194	21.00	633	32.00	813	-	-	28	2.26	57	11.00	279	12.00	305	RF/RTJ#88	1.00	25	6400	2449
36"	900	51.75	1314	25.00	636	36.00	914	33.76	857	28	2.60	64	11.76	298	13.00	330	RF/RTJ#88	1.00	25	7800	3538
40"	1000	52.00	1321	26.00	660	38.00	914	-	-	32	2.26	57	12.60	318	-	-	RF	1.50	38	8100	3674
42"	1050	55.25	1403	27.80	701	38.00	966	39.60	1003	28	2.60	64	13.60	343	-	-	RF	1.50	38	9800	4366

Lug Type - ASME Class 900

Size		Dimensions								Stud details						End facing	Hook screw hole size		Weight		
		A		B		D		E		No.	Diameter		RF Stud length		RFJ Stud length		In	mm	lbs	kg	
NPS	DN	In	mm	In	mm	In	mm	In	mm		In	mm	In	mm	In	mm					In
2"	50	8.50	216	2.75	70	2.38	80	1.69	43	8	0.88	22	4.25	108	4.75	121	RF/RTJ#24	-	-	37	17
3"	80	9.50	241	3.25	83	2.91	74	2.63	67	8	0.88	22	4.00	102	4.50	114	RF/RTJ#31	-	-	60	27
4"	100	11.50	292	4.00	102	4.50	114	3.44	87	8	1.13	29	5.00	127	5.50	140	RF/RTJ#37	-	-	95	43
6"	150	15.00	381	6.25	159	6.63	163	5.19	132	12	1.13	29	5.25	133	5.75	146	RF/RTJ#45	0.50	13	255	116
8"	200	18.50	470	8.13	207	8.63	219	6.81	173	12	1.38	35	6.25	159	6.75	171	RF/RTJ#49	0.50	13	480	218
10"	250	21.50	546	9.50	241	10.75	273	8.50	216	16	1.38	35	6.50	165	7.00	178	RF/RTJ#53	0.50	13	730	331
12"	300	24.00	610	11.50	292	12.75	324	10.13	257	20	1.38	35	6.75	171	7.25	184	RF/RTJ#57	0.75	19	850	386
14"	350	25.25	641	14.00	356	14.00	356	11.50	292	20	1.50	38	7.25	184	7.75	197	RF/RTJ#62	0.75	19	1250	567
16"	400	27.75	705	15.13	384	16.00	406	12.81	325	20	1.63	41	7.75	197	8.50	216	RF/RTJ#68	1.00	25	1850	748
18"	450	31.00	787	17.75	451	18.00	457	14.44	367	20	1.88	48	8.50	216	9.50	241	RF/RTJ#70	1.00	25	2600	1134
20"	500	33.75	857	17.75	451	20.00	508	17.94	456	20	2.00	51	9.25	235	10.00	254	RF/RTJ#74	1.00	25	2900	1316
24"	600	41.00	1041	19.50	495	24.00	610	21.50	546	20	2.50	64	11.00	279	12.00	305	RF/RTJ#78	1.00	25	4400	1996

Lug Type - ASME Class 1500

Size		Dimensions								Stud details						End facing	Hook screw hole size		weight		
		A		B		D		E		No.	Diameter		RF Stud length		RFJ Stud length		In	mm	lbs	kg	
NPS	DN	In	mm	In	mm	In	mm	In	mm		In	mm	In	mm	In	mm					In
2"	50	8.50	216	2.75	70	2.38	80	1.69	43	8	0.88	22	4.25	108	4.75	121	RF/RTJ#24	-	-	35	16
3"	80	10.50	267	3.25	83	2.91	74	2.63	67	8	1.13	29	5.25	133	5.75	146	RF/RTJ#35	0.38	10	71	32
4"	100	12.25	311	4.00	102	4.50	114	3.44	87	8	1.25	32	6.00	152	6.25	159	RF/RTJ#38	0.50	13	150	68
6"	150	15.50	394	6.25	159	6.63	163	5.19	132	12	1.38	35	7.25	184	7.75	197	RF/RTJ#46	0.50	13	265	120
8"	200	19.00	483	8.13	207	8.63	219	6.81	173	12	1.63	41	8.25	210	9.00	229	RF/RTJ#50	0.75	19	625	284
10"	250	23.00	584	9.75	248	10.75	273	8.50	216	12	1.88	48	9.50	241	10.25	260	RF/RTJ#54	0.75	19	798	362
12"	300	26.50	673	12.00	305	12.75	324	10.13	257	16	2.00	51	10.50	267	11.50	292	RF/RTJ#58	0.75	19	1400	635
14"	350	29.50	749	14.00	356	14.00	356	11.50	292	16	2.25	57	11.50	292	12.75	324	RF/RTJ#63	1.00	25	2400	1089
16"	400	32.50	826	15.13	384	16.00	406	12.81	325	16	2.50	64	12.75	324	14.00	356	RF/RTJ#67	1.00	25	2500	1134
18"	450	36.00	914	18.44	468	18.00	457	13.75	349	16	2.75	70	14.00	356	16.25	387	RF/RTJ#71	1.50	38	3900	1769
20"	500	38.75	984	21.00	533	20.00	508	14.75	375	16	3.00	76	15.25	387	16.75	425	RF/RTJ#75	1.50	38	5800	2631
24"	600	46.00	1168	22.00	559	24.00	610	15.13	384	16	3.50	89	17.50	445	19.25	489	RF/RTJ#79	1.50	38	7200	3266

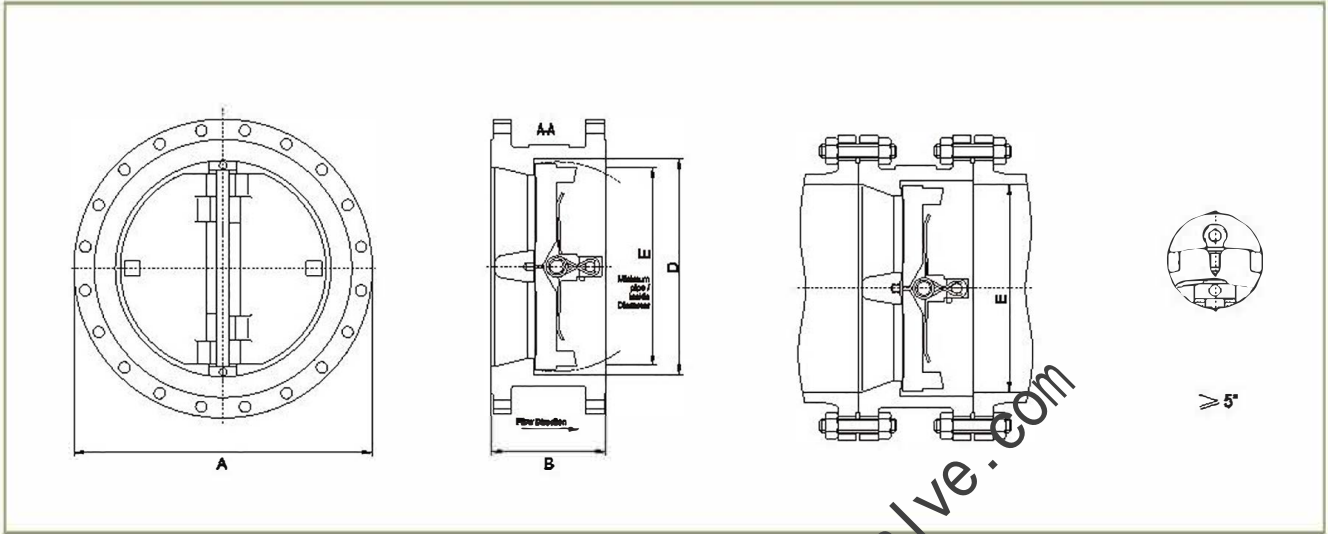

Double flanged type

Double Flanged Type - ASME Class 150

Size		Dimensions								Stud details				End facing	Weight		
		A		B		D		E		No.	Diameter		RF Stud length		lbs	kg	
NPS	DN	in	mm	in	mm	in	mm	in	mm		in	mm	in	mm			
12"	300	18.00	483	7.13	181	12.76	322	11.38	289	12	0.88	22	4.75	121	RF	279	127
14"	350	21.00	533	7.25	184	14.02	356	12.50	318	12	1.00	25	5.25	133	RF	318	145
16"	400	23.50	597	7.50	191	15.98	408	15.00	381	16	1.00	29	5.50	140	RF	387	176
18"	450	25.00	635	8.00	203	18.00	457	16.88	429	16	1.13	29	6.00	152	RF	460	209
20"	500	27.50	699	8.63	219	20.00	508	18.81	478	20	1.13	32	6.25	159	RF	600	272
24"	600	32.00	813	8.75	222	24.00	610	22.63	575	20	1.25	32	7.00	178	RF	662	301
26"	650	34.25	870	14.00	356	26.00	660	24.25	616	24	1.25	32	8.75	222	RF	1500	680
28"	700	36.50	927	18.00	381	28.00	711	-	-	28	1.25	32	9.00	229	RF	1700	771
30"	750	38.75	984	12.00	305	30.00	762	29.25	743	28	1.25	32	9.25	235	RF	1750	794
32"	800	41.75	1060	14.00	356	32.00	813	-	-	28	1.50	38	10.50	267	RF	2300	1043
36"	900	46.00	1168	14.50	368	36.00	914	35.00	889	32	1.50	38	11.25	286	RF	2925	1145
40"	1000	50.75	1288	17.00	432	40.00	1016	-	-	36	1.50	38	11.25	288	RF	3900	1769
42"	1050	53.00	1348	17.00	432	42.00	1067	41.00	1041	36	1.50	38	11.75	298	RF	4220	1914
48"	1200	58.50	1511	20.83	524	48.00	1219	47.00	1194	44	1.50	38	12.50	318	RF	5900	2676
54"	1350	68.25	1683	23.25	591	54.00	1372	51.50	1308	44	1.75	44	14.00	356	RF	7700	3493
60"	1500	73.00	1854	28.00	680	60.00	1524	56.00	1422	52	1.75	44	15.00	381	RF	10000	4536

Double Flanged Type - ASME Class 300

Size		Dimensions								Stud details				End facing	Weight		
		A		B		D		E		No.	Diameter		RF Stud length				
NPS	DN	In	mm	In	mm	In	mm	In	mm		In	mm	In	mm	In	mm	Lbs
12"	300	20.50	521	7.13	181	12.91	328	11.38	289	16	1.13	28	8.75	171	RF	336	152
14"	350	23.00	584	8.75	222	14.09	358	12.50	318	20	1.13	28	7.00	178	RF	431	195
16"	400	25.50	648	9.13	232	16.06	408	14.31	364	20	1.25	32	7.50	191	RF	675	306
18"	450	28.00	711	10.38	264	18.00	457	16.88	429	24	1.26	32	7.75	197	RF	850	388
20"	500	30.50	775	11.50	292	20.00	508	17.94	456	24	1.25	32	8.25	210	RF	1078	489
24"	600	36.00	914	12.50	318	24.00	610	21.58	548	24	1.50	38	9.25	235	RF	1965	891
28"	650	38.25	972	14.00	356	28.00	660	24.38	619	28	1.63	41	10.50	267	RF	2200	998
28"	700	40.75	1035	15.00	381	28.00	711	-	-	28	1.63	41	11.00	279	RF	2600	1179
30"	750	43.00	1092	14.50	368	30.00	762	28.75	730	28	1.75	44	11.75	298	RF	3526	1589
32"	800	45.25	1149	16.00	408	32.00	813	-	-	28	1.88	48	12.75	324	RF	3300	1487
38"	900	50.00	1270	19.00	483	36.00	914	35.00	889	32	2.00	51	13.25	337	RF	4700	2132
40"	1000	53.75	1238	21.50	548	36.00	914	-	-	32	1.63	41	13.25	337	RF	4800	2223
42"	1050	50.75	1289	22.38	568	40.00	1016	41.00	1041	32	1.63	41	13.25	349	RF	5000	2268
48"	1200	57.75	1467	24.75	629	44.00	1118	47.00	1194	32	1.88	48	15.25	367	RF	7400	3357

Double Flanged Type - ASME Class 600

Size		Dimensions								Stud details						End facing	Weight		
		A		B		D		E		No.	Diameter		RF Stud length		RFJ Stud length				
NPS	DN	In	mm	In	mm	In	mm	In	mm		In	mm	In	mm	In	mm	In	mm	Lbs
12"	300	22.00	569	9.00	229	12.75	324	11.38	289	20	1.26	32	8.50	216	9.00	229	RFRTJ#67	660	249
14"	350	23.75	603	10.75	273	14.00	358	12.50	318	20	1.38	35	9.00	229	9.50	241	RFRTJ#61	846	384
16"	400	27.00	688	12.00	306	16.00	408	14.31	364	20	1.56	38	9.75	248	10.25	260	RFRTJ#66	1010	458
18"	450	29.25	743	14.25	362	18.00	457	16.13	410	20	1.63	41	10.50	267	11.00	279	RFRTJ#69	1320	599
20"	500	32.00	813	14.50	368	20.00	608	17.94	468	24	1.83	41	11.25	286	11.75	298	RFRTJ#73	1700	771
24"	600	37.00	940	17.25	438	24.00	810	21.58	548	24	1.83	41	12.25	311	13.00	330	RFRTJ#77	2580	1170
26"	650	40.00	1018	16.00	457	25.00	680	24.00	610	28	1.88	48	13.25	337	14.25	362	RFRTJ#93	3100	1406
28"	700	42.25	1073	19.00	483	28.00	711	-	-	28	2.00	51	14.00	356	15.00	381	RFRTJ#94	3800	1724
30"	750	44.50	1130	19.88	506	30.00	762	28.75	730	28	2.00	51	14.00	366	15.00	381	RFRTJ#96	5390	2445
32"	800	47.00	1194	21.00	533	32.00	813	-	-	28	2.25	57	14.75	375	16.00	406	RFRTJ#98	6000	2722
36"	900	51.75	1314	25.00	636	36.00	914	33.75	857	28	2.50	64	16.00	406	17.00	432	RFRTJ#98	6700	3039
42"	1050	55.25	1403	27.60	701	38.00	965	39.50	1003	28	2.50	64	19.50	495	-	-	RF	9400	4264

Double Flanged Type - ASME Class 900

Size		Dimensions								Stud details						End facing	Weight		
		A		B		D		E		No.	Diameter		RF Stud length		RFJ Stud length				
NPS	DN	In	mm	In	mm	In	mm	In	mm		In	mm	In	mm	In	mm	In	mm	Lbs
12"	300	24.00	610	11.50	292	12.75	324	10.13	257	20	1.38	35	8.75	222	9.25	235	RF/RTJ#57	770	349
14"	350	25.25	641	14.00	358	14.00	358	11.50	292	20	1.50	38	9.25	235	10.00	254	RF/RTJ#62	1240	562
16"	400	27.75	705	15.13	384	16.00	406	12.81	325	20	1.63	41	10.00	254	10.75	273	RF/RTJ#66	1210	549
18"	450	31.00	787	17.75	451	18.00	457	14.44	367	20	1.88	48	11.00	279	11.75	298	RF/RTJ#70	1845	837
20"	500	33.75	857	17.75	451	20.00	508	17.94	456	20	2.00	51	12.00	305	12.75	324	RF/RTJ#74	3940	1787
24"	600	41.00	1041	19.50	495	24.00	810	21.50	546	20	2.50	64	14.00	356	15.00	381	RF/RTJ#76	4175	1894

Note:

1. A = OD 2. B = F to F 3. D = ID 4. E = Minimum ID 5. Yellow part is amended by technical Dept. 6. Above data are originated from Velan catalogue VEL-PQCV-2006