

WAFER TYPE BUTTERFLY VALVE RUBBER LINED



FEATURES

PN10 / PN16 / 125LB / 150LB / JIS10K / 150PSI / 200PSI

Size: 1-1/2"~56" (40~1400mm)

Materials: A126 B (GG25), A536 65-45-12 (GGG40), A216 WCB, S.S.304(CF8), S.S.316(CF8M), B148 C954

Simple and compact construction

Small in size and light in weight

Quick 90° on-off operation, low torque

Good sealing capability, no leakage

Matching flanges: ANSI B16.1, EN 1092, JIS10K, AS 2129

Face to face: ANSI B16.10, EN 558-1, API609

Top flange: ISO 5211

Inspection & testing: API598, GB13927

Design: ASME B16.34

Applicable medium: water, sewage, sea water, air, corrosive liquids

Applicable temperature: -45°C~+150°C (higher temperature is available upon request)

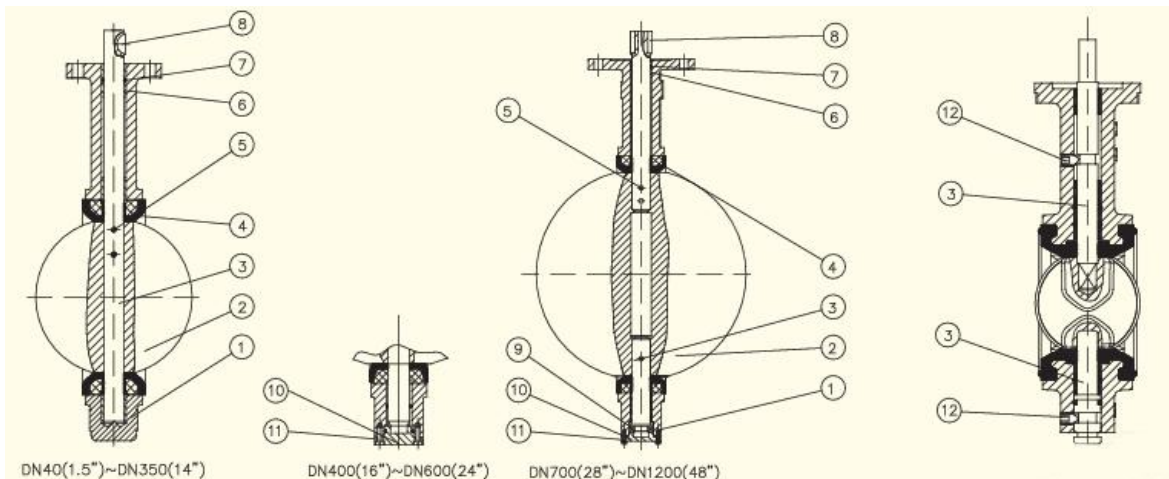

PARTS AND MATERIALS

NO.	PARTS	MATERIALS
1	Body	C.I., D.I., WCB, ALB, CF8 (S.S.304), CF8M (S.S.316)
2	Disc	D.I., CF8 (S.S.304), CF8M (S.S.316), ALB, Duplex S.S., Hastelloy Alloy, Monel
3	Stem	SUS416, SUS304, SUS316, SUS431, 17-4PH
4	Seat	NR, NBR, EPDM, VITON
5	Taper pin	SUS416, SUS316, SUS431, 17-4PH
6	Bushing	Bronze, PTFE
7	O-Ring	NBR, EPDM
8	Key	45#, 1045
9	Bearing	Bearing Steel
10	End cover	C.I., WCB, CF8 (S.S.304), CF8M (S.S.316)
11	Bolt	Q235, Gr.33, 35#, 1035, SUS304
12	Hex. screw	Q235-A, Gr.33

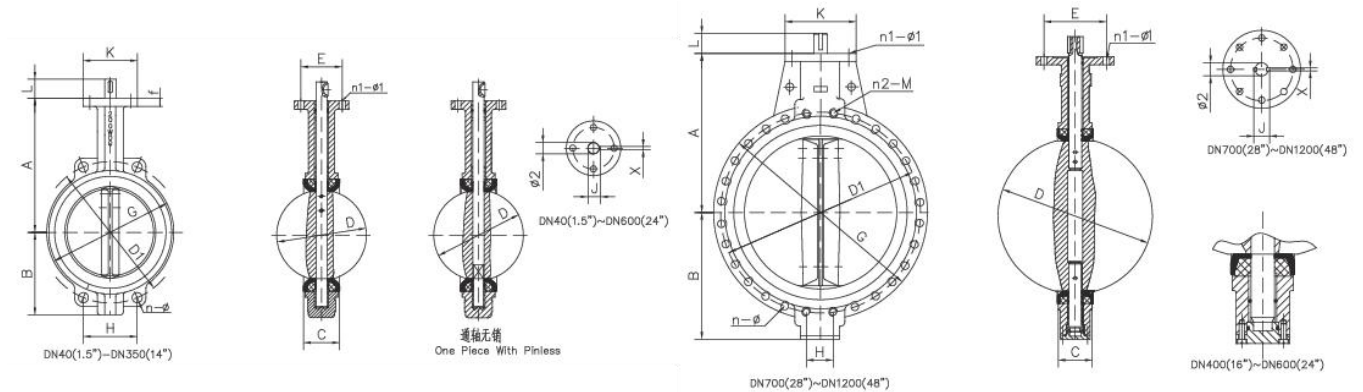

MAIN CONNECTION DIMENSIONS

SIZE		A	B	C	D	L	H	D1	n-Ø	K	E	n1-Ø1	Ø2	G	n2-M	f	J	X	Weight (Kgs)
(mm)	(inch)																		
40	1.5	145	70	33	43	28	77.77	110	4-18	65	50	4-7	12.6	100	-	13	13.8	3	2.3
50	2	161	80	43	53	28	84.84	120	4-23	65	50	4-7	12.6	100	-	13	13.8	3	2.8
65	2.5	175	89	46	64	28	96.2	136.2	4-26.5	65	50	4-7	12.6	120	-	13	13.8	3	3.5
80	3	181	95	46	79	28	61.23	160	8-18	65	50	4-7	12.6	127	-	13	13.8	3	3.7
100	4	200	114	52	104	28	70.8	185	4-24.5	90	70	4-10	15.77	156	-	13	17.77	5	5.4
125	5	213	127	56	123	28	82.28	215	4-23	90	70	4-10	18.92	190	-	13	20.92	5	7.7
150	6	226	139	56	156	28	91.08	238	4-25	90	70	4-10	18.92	212	-	13	20.92	5	9.3
200	8	260	175	60	202	38	112.89	295	4-25	125	102	4-12	22.1	268	-	15	24.1	5	14.5
							76.35		4-23										
250	10	292	203	68	250	38	92.4	357	4-29	125	102	4-12	28.45	325	-	15	31.45	8	23
300	12	337	242	78	302	38	105.34	407	4-29	125	102	4-12	31.6	403	-	20	34.6	8	36





Shanghai Luokai Industrial Co., Ltd.

No.218 Huting Road (N), Shanghai, China 201615

Tel: +86 21 5603 2171 Fax: +86 21 3325 0914

sales@lokvalve.com www.lokvalve.com

350	14	368	267	78	333	45	91.11	467	4-30	150	125	4-14	31.6	436	-	20	34.6	8	45
400	16	400	325	102	390	51	100.47	515	4-26	175	140	4-18	33.15	488	-	22	36.15	10	65
						60	102.42	525	4-30										
450	18	422	345	114	441	51	88.39	565	4-23	175	140	4-18	37.95	536	-	22	40.95	10	86
						60	91.51	585	4-30										
500	20	480	378	127	492	57	86.99	620	4-26	175	140	4-18	41.15	590	-	22	44.15	10	113
						75	101.68	650	4-33										
600	24	562	475	154	593	70	113.42	725	20-30	210	165	4-22	50.62	816	-	22	54.65	16	209
						75	120.46	770	20-36										
700	28	624	543	165	695	66	109.65	840	24-30	300	254	8-18	63.35	895	-	30	71.4	18	292
						70			24-36					910					
800	32	672	606	190	795	66	124	950	24-33	300	254	8-18	63.35	1015	-	30	71.4	18	396
						75			24-39					1025					
900	36	720	670	203	865	110	117.57	1050	24-36	300	254	8-18	75	1115	4-M30	34	84	20	520
									24-39					1125	4-M36				
1000	40	800	735	216	965	135	129.89	1160	24-36	300	254	8-18	85	1230	4-M33	35	95	22	668
							130.99	1170	24-43					1255	4-M39				
1200	48	941	878	254	1160	150	135.26	1380	28-39	350	298	8-22	105	1455	4-M36	35	117	28	1080
							136.24	1390	28-49					1485	4-M45				

NOTES:

As we are constant endeavoring to improve the performance of our equipment.

The company reserves the right to make alteration from time to time and equipment differ from that detailed in this brochure.



WRAS