

ANSI FLANGED Y TYPE STRAINER

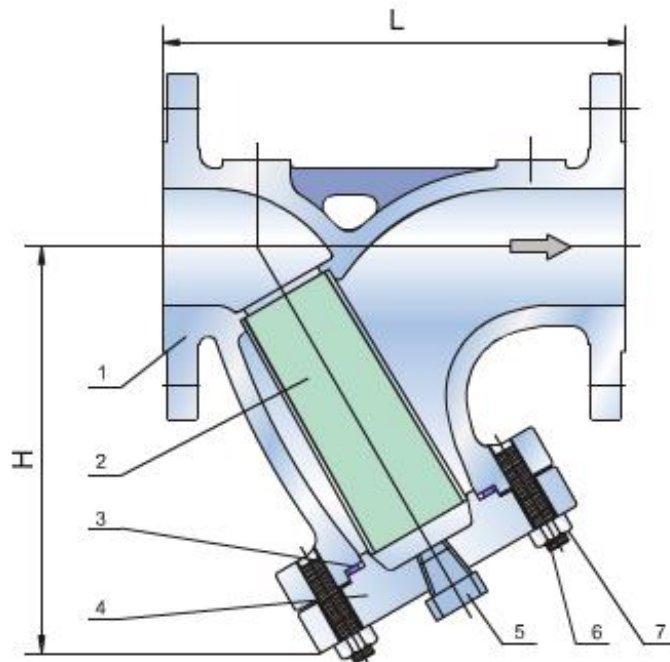

FEATURES

- PN: 10K
- Size: 1/2"~12" (15~300mm)
- Materials: A216 WCB, A351 CF8 (S.S.304), A351 CF8M (S.S.316)
- Face to face: JIS B2072, B2084
- Flanged ends: JIS B2212, B2214
- Inspection & testing: JIS B2003
- Design: JIS B2074, B2081
- Applicable medium: water, oil, gas
- Applicable temperature: ≤300°C



PARTS AND MATERIALS

ITEM	PART NAME	MATERIAL
1	Body	ASTM A216 GR.WCB, A351 CF8 (S.S.304), A351 CF8M (S.S.316)
2	Screen	ASTM A276 Type 304
3	Gasket	304+Graphite, 316+Graphite
4	Cover	ASTM A216 GR.WCB, A351 CF8 (S.S.304), A351 CF8M (S.S.316)
5	Plug	ASTM A105, S.S.304, S.S.316
6	Cover Bolts	ASTM A193 GR.B7, A193-B8, B8M
7	Cover Bolt Nuts	ASTM A194 GR.2H, 8, 8M

MAIN CONNECTION DIMENSIONS
10K

Size		L	H	D	D1	D2	N-d
in	mm	mm	mm	mm	mm	mm	mm
1/2"	15A	120	70	95	70	51	4-15
3/4"	20A	125	77	100	75	56	4-15
1"	25A	155	82	125	90	67	4-19
1-1/4"	32A	170	95	135	100	76	4-19
1-1/2"	40A	182	102	140	105	81	4-19
2"	50A	200	125	155	120	96	4-19
2.5"	65A	285	165	175	140	116	4-19
3"	80A	302	200	185	150	126	8-19
4"	100A	377	215	210	175	151	8-19
6"	150A	442	305	280	240	212	8-23
8"	200A	540	410	330	290	262	12-23
10"	250A	668	490	400	355	324	12-25
12"	300A	762	580	450	400	368	16-25

NOTES:

As we are constant endeavoring to improve the performance of our equipment.

The company reserves the right to make alteration from time to time and equipment differ from that detailed in this brochure.