

DIN CAST STEEL GATE VALVE



FEATURES & SPECIFICATIONS

PN: 1.6 / 2.5 / 4.0MPa

Size: 1-1/2"~24" (40~600mm)

Full bore design

OS&Y, outside screw and yoke

Rising stem and non-rising hand wheel

BB, bolted bonnet

Flexible wedge (40mm ~ 50mm solid) , fully guided

Choice of solid or split wedge

Renewable seat rings

Forged T-head stem

By pass on request

Available with gear operator

Design: DIN3352

Face to face: DIN3202-F5 / DIN3202-F7 / EN558-1

End flange: DIN2543 PN16 / DIN2544 PN25 / DIN2545 PN40 / EN1092-1

Inspection & testing: DIN3230 / EN12266-1

Applicable medium: water, oil, gas

Applicable temperature: -29°C~+425°C



Cast Steel Gate Valves with fixed handwheel and rising stem (outside screw and yoke) (OS&Y)

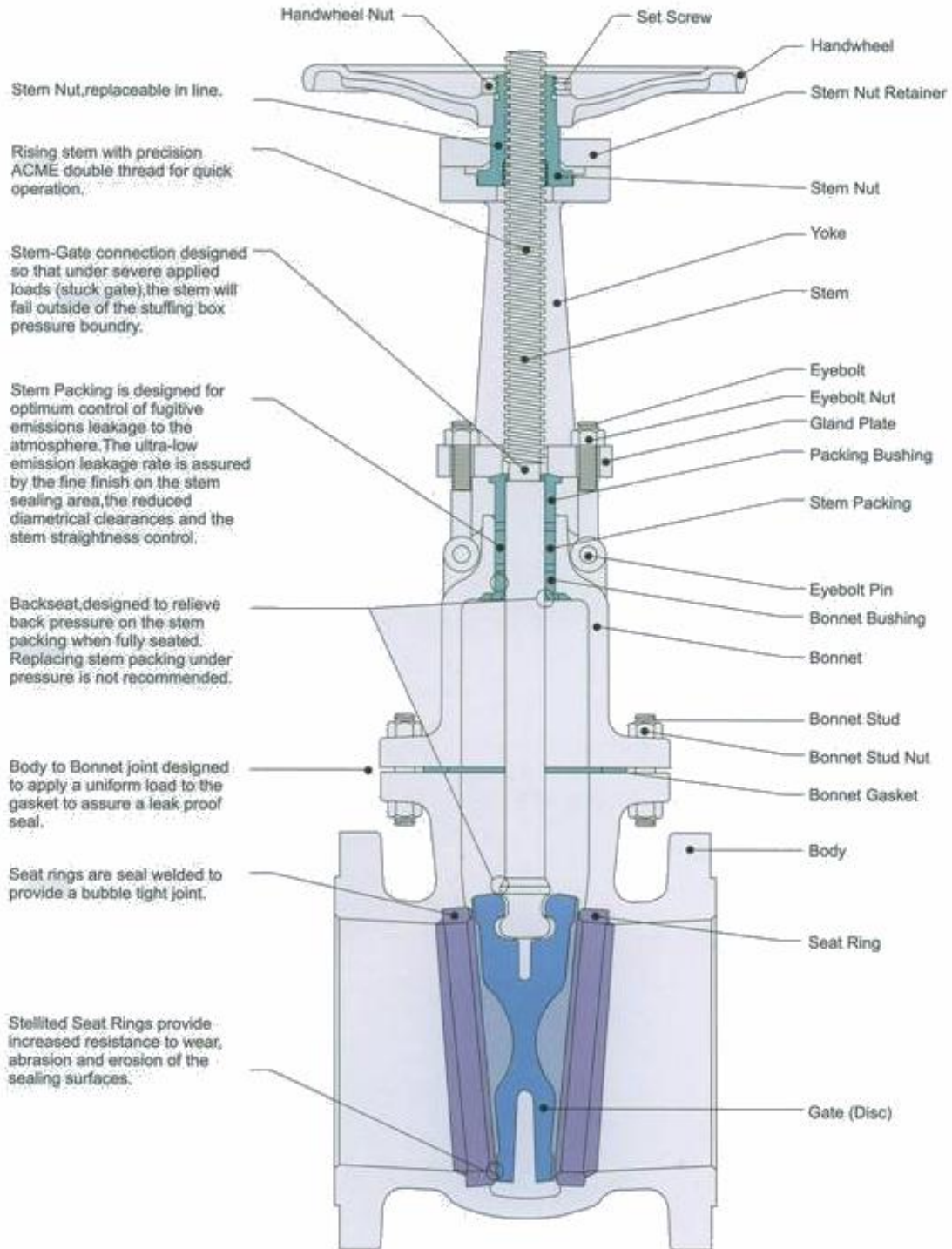

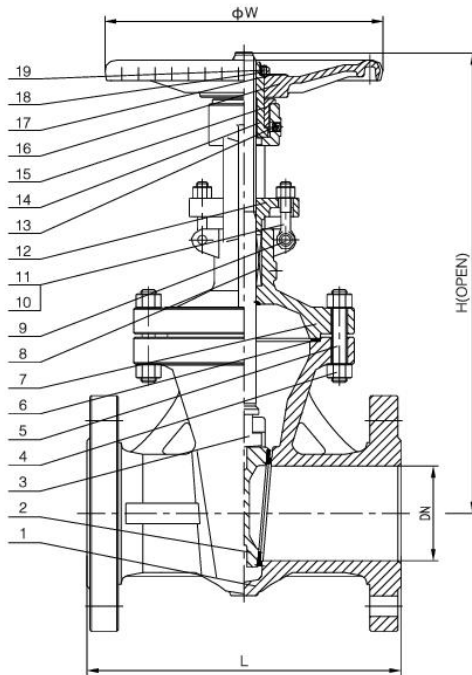

MAIN PARTS AND MATERIALS

ITEM	PARTS	MATERIALS
1	Body	GS-C25 + 13Cr Faced
2	Wedge	GS-C25 + 13Cr Faced
3	Stem	ASTM A182 GR.F6a
4	Bonnet Bolt Nuts	ASTM A194 GR.2H
5	Bonnet Bolts	ASTM A193 GR.B7
6	Gasket	S.S. + Flexible Graphite
7	Bonnet	GS-C25
8	Stem Packing	Braided Graphite & Die Formed Graphite Ring
9	Eye Bolt Pins	Die formed Graphite Ring Carbon Steel
10	Gland Eye Bolts	ASTM A193 GR.B7
11	Gland Eye Nuts	ASTM A194 GR.2H
12	Gland	ASTM A276 Type 410
13	Grease Nipple	Carbon Steel
14	Stem Nut	ASTM A439 GR.D-2
15	Retaining Nut	Carbon Steel
16	Hand wheel	Ductile Iron
17	Name plate	Stainless Steel
18	Hand wheel Nut	Carbon Steel
19	Grub Screw	Carbon Steel



DIMENSIONS & WEIGHTS

PN	DN	40	50	65	80	100	125	150	200	250	300	350	400	500	600
16	L	240	250	270	280	300	325	350	400	450	500	550	600	700	800
	H	365	410	432	498	565	678	790	980	1190	1410	1550	1750	1900	2600
	W	180	200	220	250	280	300	300	350	400	450	500	550	700	800
	Weight (Kgs)	15	20	29	34	45	65	90	135	205	330	450	689	948	1420
25	L	240	250	270	280	300	325	350	400	450	500	550	600	700	800
	H	365	410	440	498	585	695	802	990	1200	1420	1560	1760	2180	2610
	W	180	200	220	250	280	300	300	350	400	450	500	550	700	800
	Weight (Kgs)	17	21	32	35	50	75	95	155	242	345	472	695	1142	1450
40	L	240	250	290	310	350	400	450	550	650	750	850	950	1150	1350
	H	365	420	452	498	595	708	810	1010	1220	1440	1580	1780	2200	2630
	W	180	200	220	250	280	300	300	350	400	450	500	550	700	800
	Weight (Kgs)	18	22	30	38	51	70	110	223	270	500	665	850	1350	1609
63	L	240	250	290	310	350	400	450	550	650	750	850	950	1150	1350
	H	365	440	480	525	625	740	810	1045	1260	1490	1630	1840	2260	2720
	W	180	200	250	250	280	400	450	500	500	600	650	700	800	900
100	L		250	290	310	350	400	450	550	650	750	850	950		
	H		460	500	550	660	765	850	1090	1310	1550	1710	1920		
	W		220	250	280	300	400	450	500	550	600	650	700		
160	L		300	360	390	450	525	600	750						
	H		612	677	686	751	868	997	1224						
	W		350	400	400	500	550	650	750						

Notes:

As we are constant endeavoring to improve the performance of our equipment.

The company reserves the right to make alteration from time to time and equipment differ from that detailed in this brochure.

