

CAST STEEL Y STRAINER

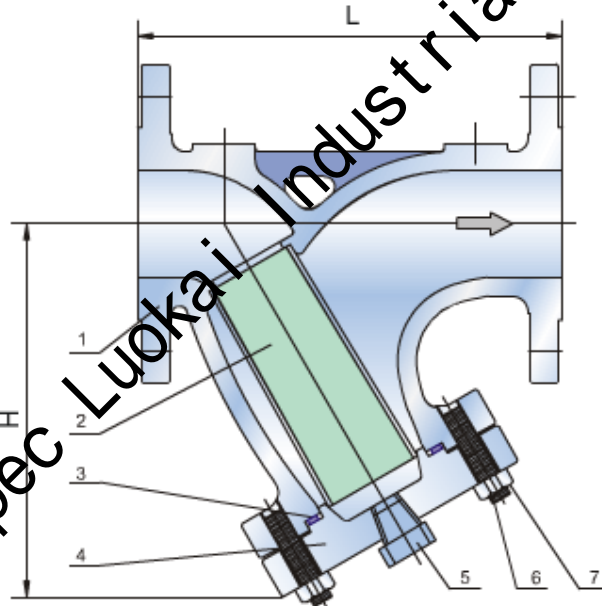

FEATURES & SPECIFICATIONS

Design	ASME B16.34
Face to Face	ASME B16.10
End Flange	ASME B16.5
Test	API 598



STANDARD MATERIALS OF MAIN PARTS

ITEM	PART NAME	MATERIAL
1	Body	ASTM A216 GR.WCB, A351 CF8, CF8M, CF3, CF3M
2	Screen	ASTM A276 Type 304
3	Gasket	304+Graphite
4	Cover	ASTM A216 GR.WCB, A351 CF8, CF8M, CF3, CF3M
5	Plug	ASTM A105, AISI304, AISI316
6	Cover Bolts	ASTM A193 GR. B7, A193 GR. B8, B8M
7	Cover Bolt Nuts	ASTM A194 GR.2H, A194 GR. 8, 8M



DIMENSIONS & WEIGHTS

CLASS 150

Size		L		H		Weight
in	mm	in	mm	in	mm	kg
2"	50	8.00	203	5.71	145	12
2.5"	65	8.50	216	7.20	183	18
3"	80	9.50	241	8.11	206	21
4"	100	11.50	292	8.98	228	32
6"	150	16.00	406	12.95	329	48
8"	200	19.50	495	17.32	440	105
10"	250	24.50	622	19.96	507	169
12"	300	27.50	699	23.39	594	215

DIMENSIONS & WEIGHTS

CLASS 300

Size		L		H		Weight
in	mm	in	mm	in	mm	kg
2"	50	10.50	267	6.70	170	15
2.5"	65	11.50	292	7.28	185	18
3"	80	12.50	318	9.25	235	35
4"	100	14.00	356	11.42	290	51
6"	150	17.50	445	14.76	375	92
8"	200	22.00	559	17.72	450	182
10"	250	24.50	622	22.64	575	285
12"	300	28.00	711	26.18	665	307

DIMENSIONS & WEIGHTS

CLASS 600

Size		L		H		Weight
in	mm	in	mm	in	mm	kg
2"	50	11.50	292	7.28	185	35
2.5"	65	13.00	330	7.87	200	40
3"	80	14.00	356	9.84	250	48
4"	100	17.00	432	11.81	300	90
6"	150	22.00	559	16.34	415	220
8"	200	26.00	660	19.29	490	360
10"	250	31.00	787	23.43	595	500
12"	300	33.00	838	26.77	680	781

NOTES:

As we are constant endeavoring to improve the performance of our equipment. The company reserves the right to make alteration from time to time and equipment differ from that detailed in this brochure.