



2PC FLOATING BALL VALVE JIS FLANGED



FEATURES

JIS10K

15A~300A

Materials: SCS13A/SCS14A

Full port, fully opening or closing

Blow-out proof stem, anti-static device

Two pieces structure, easy operation and maintenance

PED97/23/EC (CE0035) approved

Investment casting approved to AD2000-WO certificate

Face to face: JIS B2002

Flanged ends: JIS B2238

Design: JIS B2002

Inspection & testing: JIS B2003

Applicable medium: water, oil, gas, corrosive liquids

Applicable temperature: -29°C~120°C (higher temperature is available upon request)

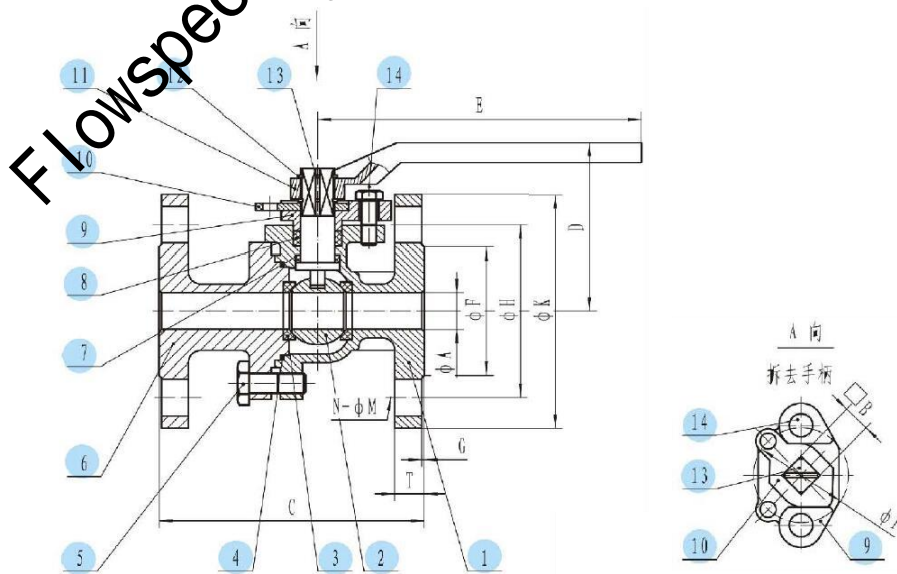



PARTS AND MATERIALS

No.	Part	Material
1	Body	SCS13A, SCS14A
2	Ball	SCS13A, SCS14A
3	Seat	RTPFE
4	Body seat	PTFE
5	Bolt	SUS304
6	Cap	SCS13A, SCS14A
7	Stem seal	PTFE
8	Stem packing	PTFE
9	Gland	SCS13A, SCS14A
10	Stopper	SUS304
11	Handle	SUS304
12	Spring washer	SUS304
13	Stem	SUS304
14	Bolt	SUS304

MAIN CONNECTION DIMENSIONS

FULL BORE

JIS 10K

DN	A	B	D	E	P	F	H	K	T	G	M	N	C
mm	mm	mm	mm	mm	mm	mm	mm	mm	mm	mm	mm	mm	mm
15A	15	11	73	130	42	52	70	95	12	1	15	4	108
20A	20	11	76	130	42	58	75	100	14	1	15	4	117
25A	25	14	86	150	50	70	90	125	14	1	19	4	127
32A	32	14	91	160	50	80	100	135	16	2	19	4	140
40A	38	17	119	200	70	85	105	140	16	2	19	4	165
50A	50	17	127	200	70	100	120	155	16	2	19	4	178
65A	65	22	136	200	102	120	140	175	18	2	19	4	190
80A	76	22	164	325	102	130	150	185	18	2	19	8	203
100A	94	22	178	325	102	155	175	210	18	2	19	8	229