



LUOKAI
WE MAKE FLOW BETTER

2PC BALL VALVE 2000 WOG



FEATURES

2000PSI / PN125

Size: 1/4"~2"

Materials: A105, S.S.304 (CF8), S.S.316(CF8M)

Full port, fully opening or closing

Blow-out proof stem, reliable sealing

Two pieces structure, easy operation and maintenance

PED97/23/EC (CE0035) approved

Investment casting approved to AD2000-WO certificate

Threaded: G, NPT, PT, Rp, Rc (ASME B1.20.1, BS21/2799, DIN2999/259, ISO228-1, JIS B 0203, ISO7/1)

Inspection & testing: API598, EN12266, DIN3230/3

Design: ASME B16.34

Applicable medium: water, oil, gas, corrosive liquids

Applicable temperature: -29°C~120°C (higher temperature is available upon request)

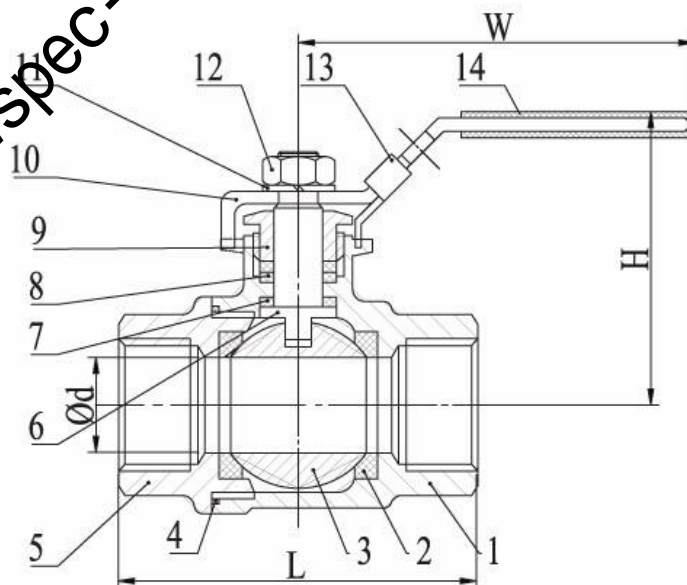

Shanghai Luokai Industrial Co., Ltd.

Add: No. 218 Huting Road (N), Shanghai, China 201615

Tel: +86 21 5603 2171

Fax: +86 21 3325 0914

E-mail: sales@lokvalve.com

www.lokvalve.com



PARTS AND MATERIALS

ITEM	PART	MATERIAL
1	Body	A105, CF8/CF8M,SS304,SS316
2	Ball seat	PTFE
3	Ball	CF8/CF8M,SS304,SS316
4	Body seal	PTFE
5	Cap	A105, CF8/CF8M,SS304,SS316
6	Stem	SUS304/SUS316
7	Thrust washer	PTFE
8	Packing	PTFE
9	Gland nut	SUS304
10	Handle	SUS304
11	Washer	SUS304
12	Nut	SUS304
13	Locking device	SUS304
14	Plastic cover	Plastic

MAIN CONNECTION DIMENSIONS

SIZE	d	L	H	W
1/4"	12.5	56.5	48	105
3/8"	12.5	56.5	48	105
1/2"	15	65.5	53	110
3/4"	20	77.5	62	135
1"	25	89.0	75	150
1-1/4"	32	104.0	82.5	150
1-1/2"	38	122.0	91	177
2"	50	124.5	102	183

NOTES:

1. As we are constant endeavoring to improve the performance of our equipment.
2. The company reserves the right to make alteration from time to time and equipment differ from that detailed in this brochure.