



2PC BALL VALVE WITH MOUNTING PAD



FEATURES

1000PSI / PN16~PN63

Size: 1/2"~3"

Materials: WCB, S.S.304 (CF8), S.S.316 (CF8M)

Full port, fully opening or closing

Blow-out proof stem, reliable sealing

Two pieces structure, easy operation and maintenance

ISO5211 mounting pad

PED97/23/EC (CE0035) approved

Investment casting approved to AD2000-WO certificate

Threaded: G, NPT, PT, Rp, Rc (ASME B1.9.1, BS21/2799, DIN2999/259, ISO228-1, JIS B 0203, ISO7/1)

Inspection & testing: API598, EN12266, DIN3230/3

Design: ASME B16.34

Applicable medium: water, oil, gas, corrosive liquids

Applicable temperature: -29°C~20°C (higher temperature is available upon request)

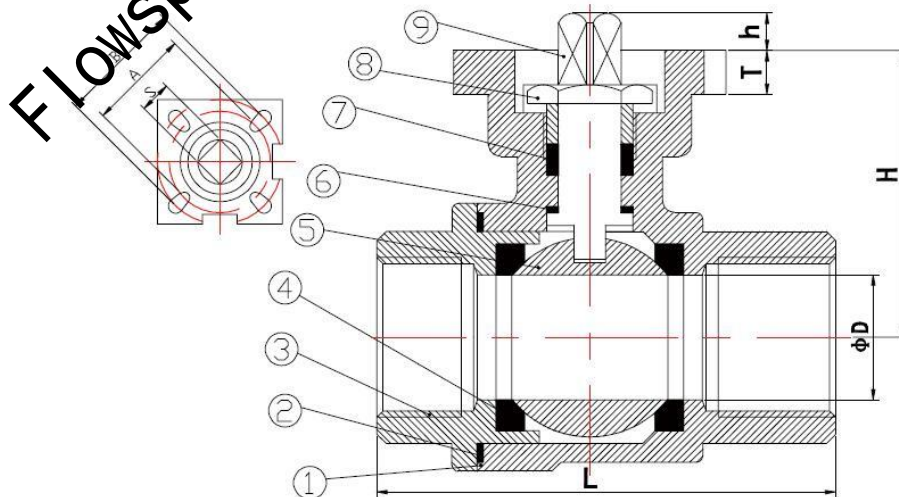



PARTS AND MATERIALS

ITEM	PART	MATERIAL
1	Body	WCB, CF8/CF8M,SS304,SS316
2	Body seal	PTFE
3	Cap	WCB, CF8/CF8M,SS304,SS316
4	Seat	PTFE
5	Ball	CF8/CF8M,SS304,SS316
6	Stem seal	PTFE
7	Stem packing	PTFE
8	Gland	SUS304
9	Stem	SUS304/SUS316

MAIN CONNECTION DIMENSIONS

SIZE	d	L	H	h	T	ISO5211		S
						A	B	
1/2"	15	64	43	9	5	F03	F04	9
3/4"	20	70	49	9	5	F03	F04	9
1"	25	85	58	11	5	F04	F05	11
1-1/4"	32	94	63	11	5	F04	F06	11
1-1/2"	38	105	71	14	6	F05	F07	14
2"	50	125	78	14	6	F05	F07	14
2-1/2"	65	155	101	17	8	F07	F10	17
3"	80	173	109	17	10	F07	F10	17

NOTES:

1. As we are constant endeavoring to improve the performance of our equipment.
2. The company reserves the right to make alteration from time to time and equipment differ from that detailed in this brochure.