



2PC BALL VALVE 1000 WOG REDUCE PORT



FEATURES

1000PSI / PN16~PN63

Size: 1/4"~3"

Materials: WCB, S.S.304 (CF8), S.S.316 (CF8M)

Reduce port, fully opening or closing

Blow-out proof stem, reliable sealing

Two pieces structure, easy operation and maintenance

PED97/23/EC (CE0035) approved

Investment casting approved to AD2000-WO certificate

Threaded: G, NPT, PT, Rp, Rc (ASME B1.20.1, BS21/2799, DIN2999/259, ISO228-1, JIS B 0203, ISO7/1)

Inspection & testing: API598, EN12266, EN13230/3

Design: ASME B16.34

Applicable medium: water, oil, gas, corrosive liquids

Applicable temperature: -29°C ~ 20°C (higher temperature is available upon request)

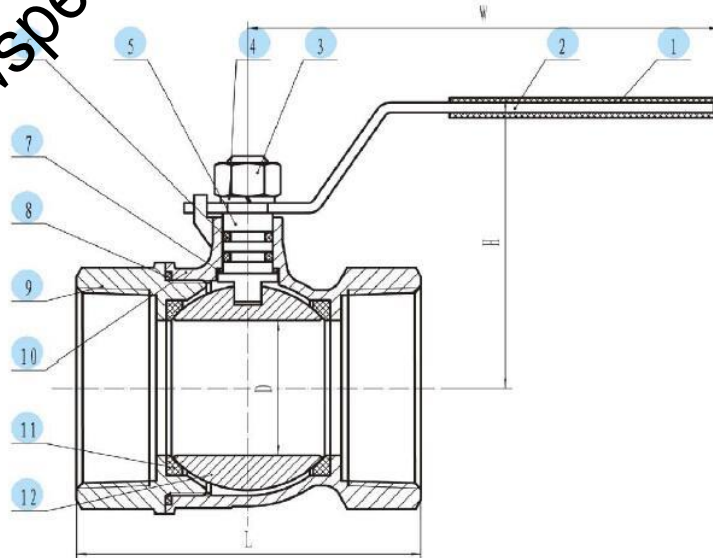



PARTS AND MATERIALS

ITEM	PART	MATERIAL
12	Ball	CF8/CF8M,SS304,SS316
11	Seat	PTFE
10	Body	WCB, CF8/CF8M,SS304,SS316
9	Cap	WCB, CF8/CF8M,SS304,SS316
8	Body seal	PTFE
7	Stem seal	PTFE
6	O-Ring	NBR
5	Stem	SUS304/SUS316
4	Thrust washer	SUS304
3	Stem nut	SUS304
2	Handle	SUS304
1	Plastic cover	Plastic

MAIN CONNECTION DIMENSIONS

SIZE	d	L	H	W
1/4"	10	52	50	106
3/8"	10	52	50	106
1/2"	10	52	50	106
3/4"	15	58	55	106
1"	20	66	62	127
1-1/4"	25	79	67	127
1-1/2"	32	89.5	81	158
2"	40	102	86	158
2-1/2"	50	132	105	167
3"	65	154	118	200

NOTES:

1. As we are constant endeavoring to improve the performance of our equipment.
2. The company reserves the right to make alteration from time to time and equipment differ from that detailed in this brochure.