



LUOKAI
WE MAKE FLOW BETTER

2PC BALL VALVE 1000 WOG DIN3203-M3



FEATURES

1000PSI / PN16~PN63

Size: 1/4"~4"

Materials: WCB, S.S.304 (CF8), S.S.316 (CF8M)

Full port, fully opening or closing

Blow-out proof stem, reliable sealing

Two pieces structure, easy operation and maintenance

PED97/23/EC (CE0035) approved

Investment casting approved to AD2000-WO certificate

Threaded: G, NPT, PT, Rp, Rc (ASME B1.20.1, BS21/2799, DIN2999/259, ISO228-1, JIS B 0203, ISO7/1)

Inspection & testing: API598, EN12266, DIN3203/3

Design: ASME B16.34

Applicable medium: water, oil, gas, corrosive liquids

Applicable temperature: -29°C~120°C (higher temperature is available upon request)

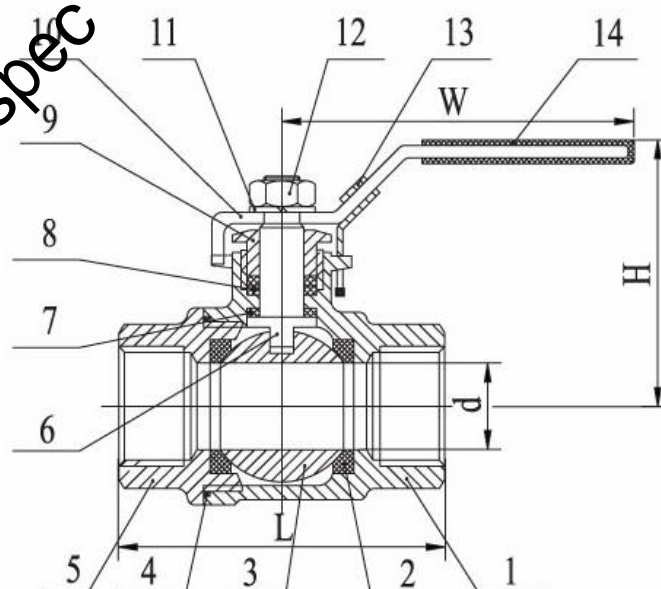

Shanghai Luokai Industrial Co., Ltd.

Add: No. 218 Huting Road (N), Shanghai, China 201615

Tel: +86 21 5603 2171

Fax: +86 21 3325 0914

E-mail: sales@lokvalve.com

www.lokvalve.com



PARTS AND MATERIALS

ITEM	PART	MATERIAL
1	Plastic cover	Plastic
2	Handle	SUS304
3	Gland nut	SUS304
4	Stem nut	SUS304
5	Thrust washer	SUS304
6	Stem packing	PTFE
7	Stem seal	PTFE
8	Body seal	PTFE
9	Cap	WCB, CF8/CF8M,SS304,SS316
10	Body	WCB, CF8/CF8M,SS304,SS316
11	Seat	RPTFE
12	Ball	CF8/CF8M,SS304,SS316
13	Stem	SUS304/SUS316

MAIN CONNECTION DIMENSIONS

SIZE	d	L	H	W
1/4"	6	50	50	100
3/8"	10	60	50	100
1/2"	15	75	52	103
3/4"	20	80	61	126
1"	25	90	65	144
1-1/4"	32	110	79	144
1-1/2"	38	120	83	189
2"	50	140	97	189
2-1/2"	65	185	120	245
3"	80	205	130	245
4"	100	240	160	278

NOTES:

1. As we are constant endeavoring to improve the performance of our equipment.
2. The company reserves the right to make alteration from time to time and equipment differ from that detailed in this brochure.